



Project _____
 AIA # _____ SIS # _____
 Item # _____ Quantity _____ C.S.I. Section 114000



4732 & 4732A Meat Choppers



MODEL

- 4732** Meat Chopper with non-removable pan
- 4732A** Meat Chopper with removable pan

STANDARD FEATURES

- + 3 HP motor
- + Compact design
- + Steel gears
- + Oil bath transmission
- + Double lip seal
- + 14 gauge stainless steel pan

ACCESSORIES

- #32 Stay-Sharp knife and plates
- #32 stuffing horns
- Floor mount legs

4732 & 4732A MEAT CHOPPERS

SPECIFIER STATEMENT

Specified unit will be an NSF rated Hobart meat chopper with 3 HP motor. Chopper features #32 attachment hub, stainless steel finish and wide mouth grinding end. Unit processes 35-40 pounds per minute and includes Stay-Sharp knife and 1/8" diameter grind plate. Additional grind plate sizes can be purchased separately. 4732 features non-removable pan and 4732A features removable pan.

Approved by _____ Date _____ Approved by _____ Date _____



SOLUTIONS/BENEFITS

PERFORMANCE

Stay-Sharp Knife & Plates

- + Hardened, alloy steel holds its edge longer than standard carbon steel
- + Can be resharpened many more times than regular plates

3 HP Motor

- + Power to handle tough jobs
- + Ample ventilation ensures cool operation and long life

EASE OF USE

Knife, Plate, and Plastic Stomper Included

- + Everything you need to start working

SANITATION & CLEANING

Heavily Tinned Cylinder, Worm, and Adjusting Ring

- + Protects against oxidation
- + Provides easy-to-clean finish

Stainless Steel Finish

- + Easy to clean and exceptionally durable

SPECIFICATIONS

Electrical: 200/60/1; 19.5 amps (4732 model only), 230/60/1; 18 amps, 200/60/3; 8.6 amps and 230/60/3; 8.1 amps – UL Listed. 380/50/3; 4.8 amps (4732 model only), 208/60/3 (4732 model only) – Not submitted for UL Listing.

Motor: 3 HP, with ball bearings, in a sealed enclosure. Front bearing lubricated by transmission, rear bearing is grease packed, sealed for life.

Transmission: Double reduction, oil-lubricated hardened helical cut steel gears. Worm speed is only 151 RPM. Thrust from chopper worm is taken by a tapered roller bearing mounted in attachment hub on face of transmission housing. Double lip seal prevents loss of oil or entrance of moisture.

Cord and Plug: Units are not furnished with a cord or plug.

Grinder End: This unit includes a #32 wide mouth grinding end. The cylinder is spiral fluted, equipped with a deep fluted worm, and is designed to use #32 plates. The cylinder, worm, and adjusting ring are heavily tinned cast iron.

Capacity: Fresh meat capacity of 35 to 40 pounds per minute, first cutting, through a 1/8 plate – and 25 to 30 pounds of beef per minute on second cutting through a 1/8 plate.

Feed Pan: Feed pan measures 34" long, 21" wide and 4¹⁵/₁₆" deep inside. Furnished in 14 gauge stainless steel. A cast aluminum guard is permanently mounted to the front and sides of the pan with hardened steel drive screws. The pan is secured to the top of the housing with screws. It is separated from the motor area by a heavy sheet of fiberglass insulation to block transfer of heat from the motor compartment to the meat.

Legs: Leg length on these standard table models provides 8" clearance between table and lowest point on adjusting ring. Legs in two different lengths (18" and 21") are available at extra cost to convert machine into a floor model. The floor model can be leveled, by adjusting the legs.

Warranty: Unit has full one-year warranty on parts, labor, and mileage against manufacturer's defects.

Weight: Unit is shipped as two separate components – the base chopper unit and the legs.

Base Unit 4732: Shipping – 318 lbs.; Net – 278 lbs.

Base Unit 4732A: Shipping – 320 lbs.; Net – 280 lbs.

5" Legs: Shipping – 6 lbs.; Net – 5 lbs.

18" Legs: Shipping – 21 lbs.; Net – 20 lbs.

21" Legs: Shipping – 22 lbs.; Net – 21 lbs.

Machine Height for Leg Options				
Legs	Dim "A"	Dim "B"	Dim "C"	Model
5-3/8" STD	27"	10-3/4"	5-3/8"	4732
	27-3/8"			4732A
18" OPT	39-5/8"	23-3/8"	18"	4732
	40"			4732A
21" OPT	42-5/8"	26-3/8"	21"	4732
	43"			4732A

DETAILS AND DIMENSIONS

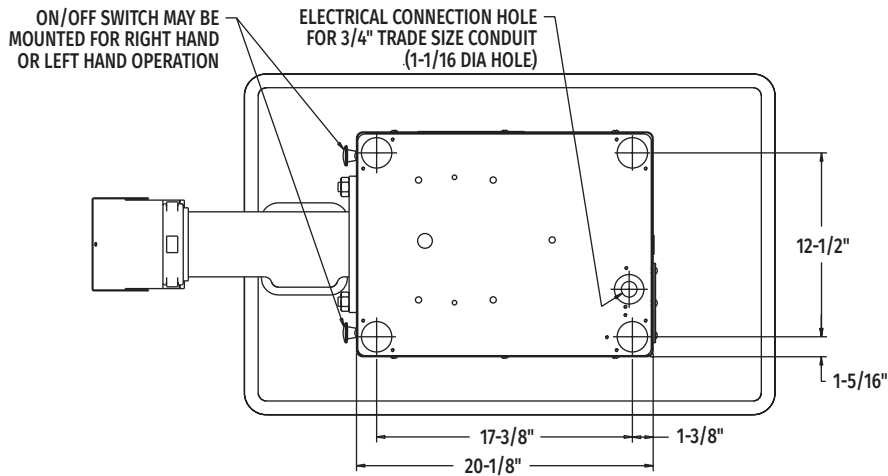
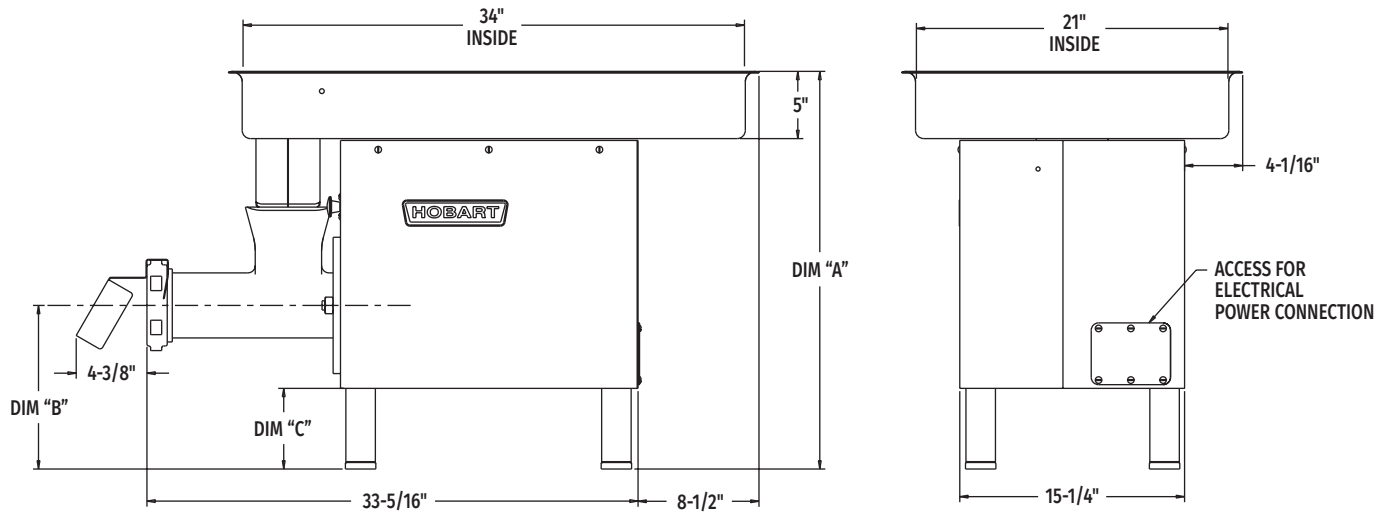

WARNING: Electrical and grounding connections must comply with the applicable portions of the National Electrical Code and/or other codes in force.