



Project _____
 AIA # _____ SIS # _____
 Item # _____ Quantity _____ C.S.I. Section 114000



6430 & 6460 Peelers



MODEL

- 6430** 30 lb. capacity peeler
- 6460** 60 lb. capacity peeler

STANDARD FEATURES

- + ¾ HP (Model 6430) or 1 HP (Model 6460) motor with manual reset thermal overload protection
- + Stainless steel finish housing
- + 5 minute timer
- + Removable NSF Lexan liner
- + Removable silicon carbon abrasive disc
- + Stainless steel drive shaft
- + Gray molded, heavy-duty hopper cover with opening to monitor product
- + Poly V-belt drive
- + Rear mounted water inlet with 5' fill hose

ACCESSORIES

- Cabinet base
- Peel trap with stainless steel strainer
- Equipment stand

6430 & 6460 - PEELERS

SPECIFIER STATEMENT

Specified unit is a UL and NSF approved peeler with 30/60 pound capacity and stainless steel finish. Unit features a 5 minute timer, removable NSF Lexan liner, removable silicon carbon abrasive disc and ¾ HP/1 HP motor with manual reset thermal overload protection.

Approved by _____ Date _____ Approved by _____ Date _____

SOLUTIONS / BENEFITS

PERFORMANCE

Stainless Steel Drive Shaft

- + Advanced design for long life and performance

Stainless Steel Finish Housing

- + Cylindrical construction heliarc-welded stainless steel

Silicon Carbide Abrasive Disc

- + 20½" diameter lightweight fiberglass reinforced plastic disc with silicon abrasive permanently bonded for high volume usage

EASE OF USE

5 Minute Timer

- + Adjusts for any increments from 30 seconds to 5 minutes, with 15 second markers on timer dial

SANITATION & CLEANING

Rear-Mounted Water Inlet with 5' Fill Hose

- + Water from inlet strikes curved surface of hopper cover, promoting interior self-cleaning and preventing undesirable splash
- + Sufficient height to meet plumbing codes

Removable NSF Lexan Liner

- + Quickly removed for cleaning

Silicon Carbide Abrasive Disc

- + Quickly removed for cleaning

OPERATOR ASSURANCE

Bowl Cover Interlock

- + Peeler will not operate unless cover is in place

Thermal Overload Protection with Manual Reset

- + Protects peeler from overheating; located on the outside of the hopper opposite the discharge chute
- + If, during operation, the motor should overheat and trip this switch, turn the timer off and allow the motor to cool for several minutes

SPECIFICATIONS

Electrical: 115/60/1, 200-230/60/1, 200-230/60/3 – UL listed.
220-240/50/1, 380-415/50/3 – not submitted for UL listing.

Motor: ¾ HP (Model 6430) or 1 HP (Model 6460), features manual reset overload protection, grease packed ball bearings, and ventilation within the peeler enclosure. Single phase is capacitor-start, induction run, and three phase is polyphase, squirrel-cage, induction-run type.

Switch: Manual tumbler type, located on right side of discharge chute as standard. Switch can be relocated to other side of chute if desired.

Drive: Multigrip, poly V-belt provides the direct speed reduction between motor and peeling disc. The stainless steel drive shaft is rigidly mounted on grease-packed ball bearings. Sealing prevents entrance of water into shaft bearings.

Peeler Unit: Cylindrical construction, heliarc-welded stainless steel with removable NSF approved Lexan liner. A one piece plastic positive locking hopper cover is provided. Quick-opening removable aluminum hopper door and positive, cam-type pressure lock. To facilitate installation, the peeler unit can be positioned at 90° intervals, in relation to the peel trap unit.

Abrasive Disc: An extremely lightweight fiberglass reinforced plastic disc is 20½" in diameter. The silicon-carbide abrasive is permanently bonded to the disc, assuring unequaled long service. Disc can be easily and quickly removed for cleaning by removing the lightweight hopper cover. Two angle mounted wipers provide positive movement of waste into the outlet.

Finish: Peeler and peel trap unit are glass-beaded stainless steel. Plastic molded hopper cover is gray. Door and handle, discharge chute, and legs are cast aluminum and ball burnished for durability. Bottom of peeler unit is cushioned in resilient rubber trim molding.

Accessories: Cabinet base and peel trap.

Warranty: Unit has full one-year warranty on parts, labor and mileage against manufacturer's defects. Service contracts are available.

Shipping Weight:

Model 6430: 157 lbs.

Model 6460: 124 lbs.

DETAILS AND DIMENSIONS – PEELER

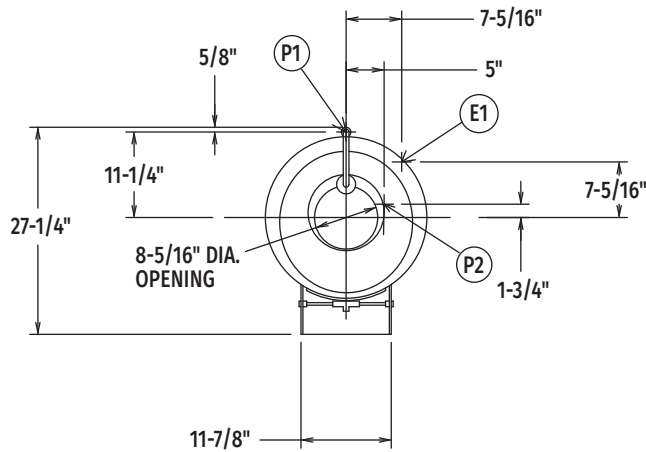

LEGEND

Electrical Connections	
E1	Electrical connection: 7/8" diameter hole (for 1/2" conduit).
Plumbing Connections	
P1	Water connection: standard 1/2" female pipe thread.
P2	Drain hose: 2-3/8" I.D. x 2-3/4" O.D.

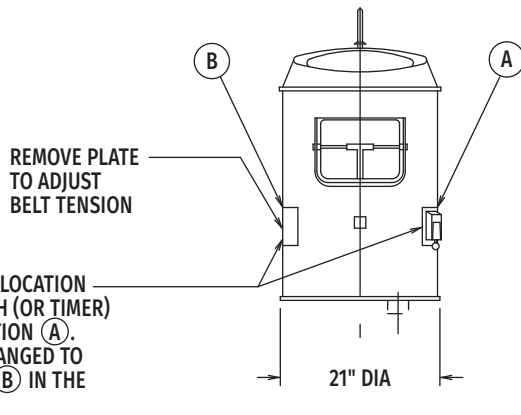

WARNING: Electrical and grounding connections must comply with the applicable portions of the National Electrical Code and/or other local electrical codes.

Plumbing connections must comply with applicable sanitary, safety and plumbing codes in force.

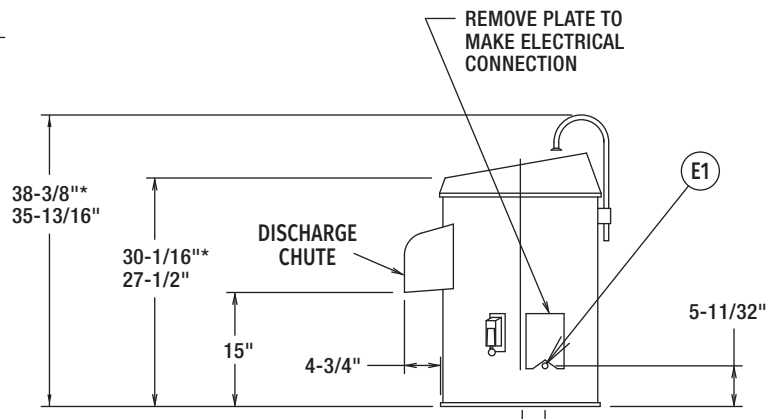
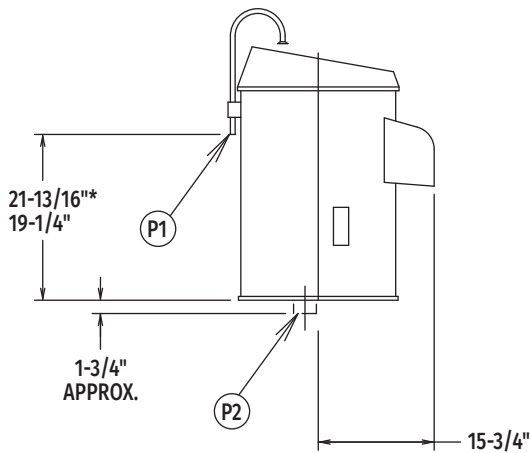

MODEL 6430 & 6430-T
MODEL 6460 & 6460-T
PEELER (WITHOUT TRAP)

Machine Voltages			
6430	115/60/1	200-230/60/1	240/50/1
Power Cord Included	No	No	No

*Indicates dimensions for 6460 & 6460-T

Machine Voltages					
6460	115/60/1	200-230/60/1	200-230/60/3	220-240/50/1	380-415/50/3
Power Cord Included	No	No	No	No	No

DETAILS AND DIMENSIONS – PEELER WITH PEEL TRAP UNIT

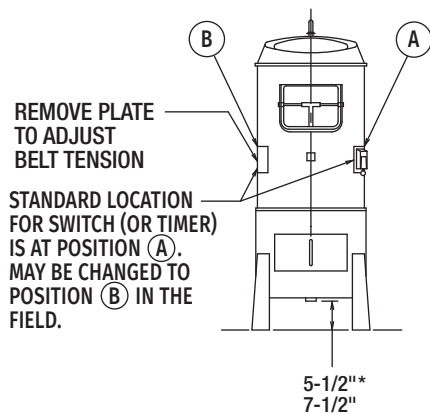
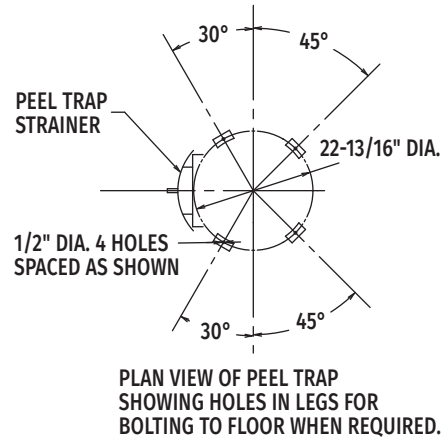
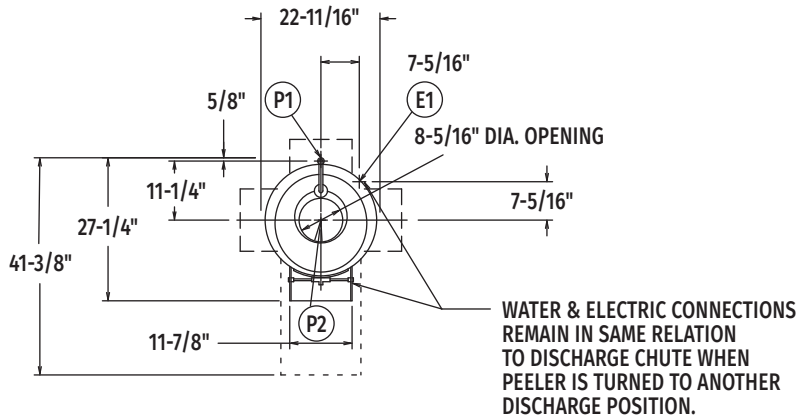

WARNING: Electrical and grounding connections must comply with the applicable portions of the National Electrical Code and/or other local electrical codes.

Plumbing connections must comply with applicable sanitary, safety and plumbing codes in force.

LEGEND

Electrical Connections	
E1	Electrical connection: 7/8" diameter hole (for 1/2" conduit).
Plumbing Connections	
P1	Water connection: standard 1/2" female pipe thread.
P2	Drain connection - standard 2" male pipe thread.

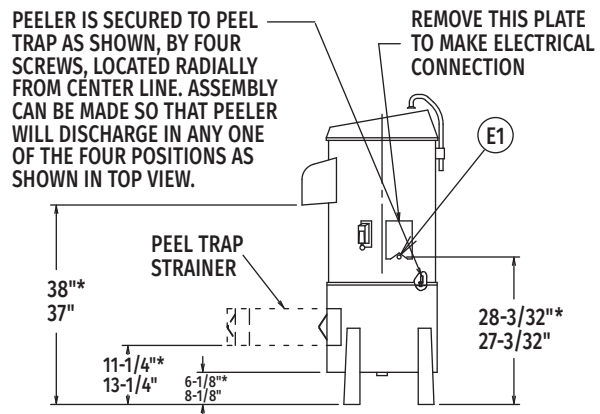
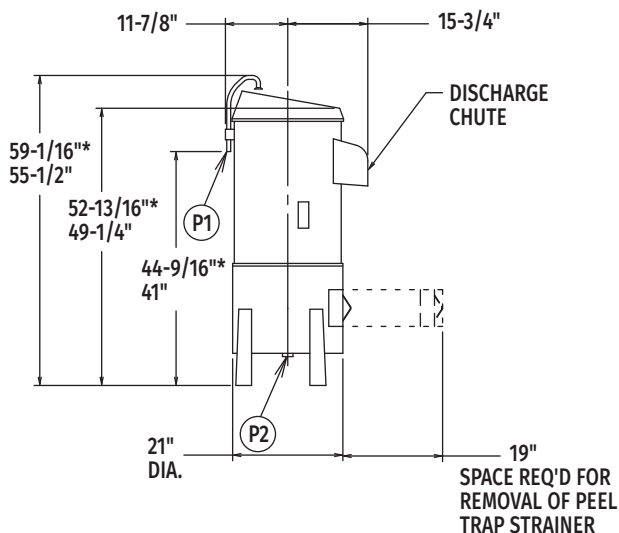

Note: All dimensions taken from floor line may be increased as much as 13/16" by leg adjustment.

*Indicates dimensions for 6460 & 6460-T