



Project _____
 AIA # _____ SIS # _____
 Item # _____ Quantity _____ C.S.I. Section 114000



CL44eN-BAS GAS

High Temperature Rack Conveyor Dishwashing Machine



SPECIFIER STATEMENT

Specified dishwasher will be Hobart CL44eN Base gas tank heat model with Opti-Rinse™. Includes insulated ergonomic cabinet style doors, dirty water indicator, configurable “intelligent” de-lime notification, top mounted computer controls, and NSF approved pot and pan cycle mode. The wash tank utilizes durable precision pressure sensor monitors in lieu of conventional mechanical floats. The 19.5" standard chamber height will accommodate up to (6) standard sheet pans at a time on an open-end sheet pan rack.

STANDARD FEATURES

- + 202 racks per hour
- + Opti-Rinse™ system
- + Rapid return conveyor drive mechanism
- + Large double door opening for ease of cleaning
- + Doors are insulated & hinged with door interlock switches
- + 19.5" chamber height opening (accepts sheet pans)
- + Top mounted micro-processor control module
- + Energy saver mode (programmable auto-shut down)
- + Dirty water indicator
- + Manager activated low temperature alert
- + NSF rated configurable pot and pan dwell mode
- + Configurable “intelligent” delime notification
- + Service diagnostics
- + Self-aligning wash manifolds
- + Stainless steel anti-clogging wash arms
- + Stainless steel self-draining pump and impeller
- + Single, sloping scrap screen and deep scrap basket
- + Stainless panels enclose perimeter and bottom
- + Door actuated drain closure
- + Convertible hot water or low temp final rinse
- + Vent fan control
- + Booster heater control

OPTIONS & ACCESSORIES (Available at extra cost)

- Standard, short and extended stainless steel vent hoods
- Internal stainless steel pressure-less 30 kW booster heater field convertible to 15 kW (booster includes PRV)
 - + Dual point electrical connection standard on 208/60/3 and 240/60/3 voltage machines, when equipped with internal electric booster; single point kits available (see page 3)
- Direct drive unloader – adds 38" length. Reference spec F39520 for more details
- Side loader – SL23 adds 23" length, SL30 adds 30" length. Reference specs F40926 and F40927 for more details
- Blower-dryer – adds 33¾" to length. Reference spec F40252 for more details (ships separate from dishmachine, contact Hobart Service for installation)
- Drain water tempering kit (field installed)
- Flanged feet kit (requires two kits)
- Table limit switch with 10' wire
- Correctional package (contact Hobart for details)
- Pressure regulator valve (PRV), for use with external booster
- Water shock absorber kit
- Factory-mounted circuit breakers (contact Hobart for details)
- Field installed single point kits available for 208/60/3 and 240/60/3 machines when equipped with internal booster

CLEAN SERIES – CL44eN-BAS GAS

Approved by _____ Date _____ Approved by _____ Date _____



CL44eN-BAS GAS

High Temperature Rack Conveyor Dishwashing Machine

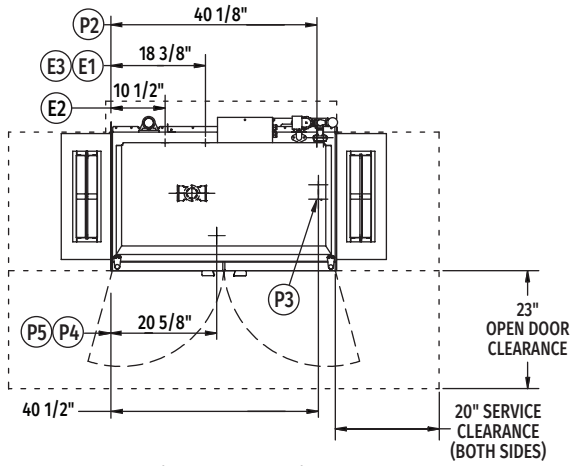

Top View Left to Right

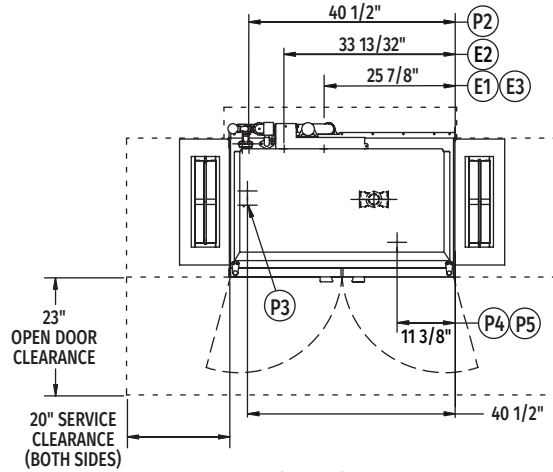

Top View Right to Left

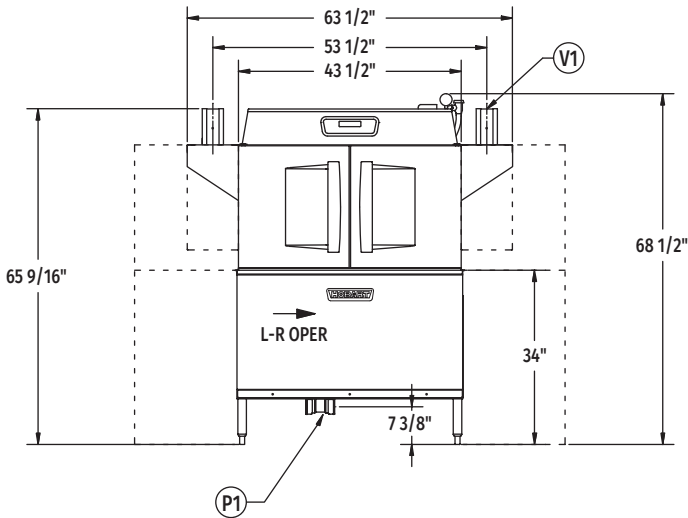

Front View Left to Right

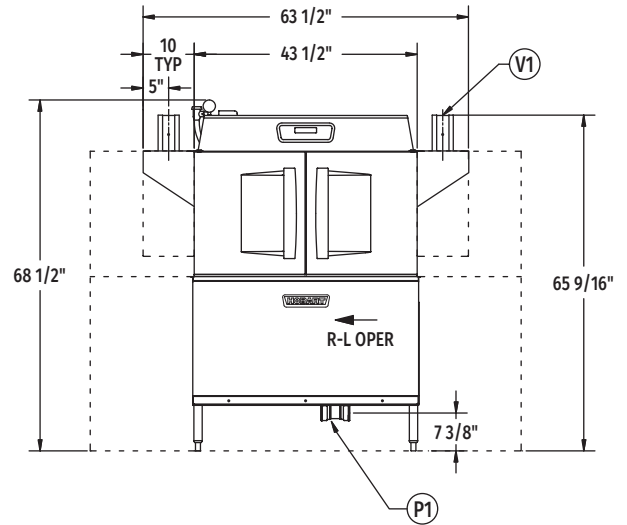

Front View Right to Left

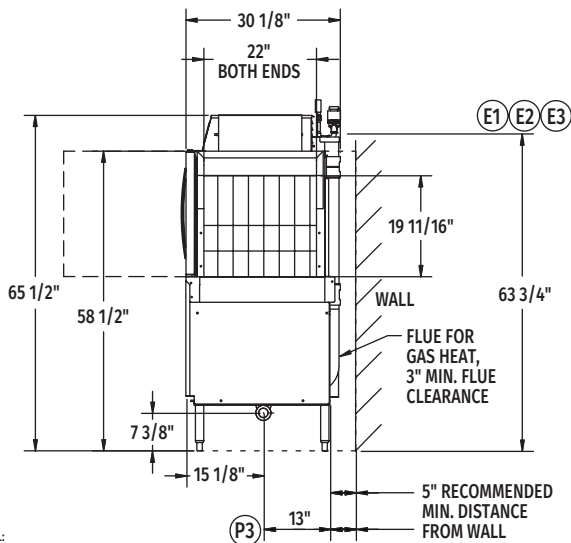

Side View

Tabling Connection: 44" inside tank (at table connection)

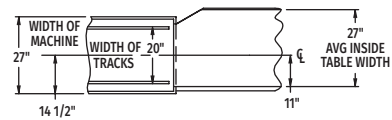

Suggested Track and Table Layout

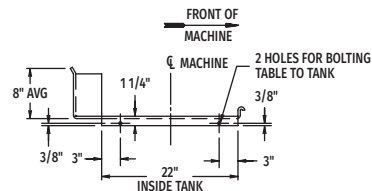

View Showing Hole Locations in Turned Down Portion of Table

MODEL-
CL44eN BASE
L-R OPERATION
D-974801
REV B

MODEL-
CL44eN BASE
R-L OPERATION
D-974800
REV B



CL44eN-BAS GAS

High Temperature Rack Conveyor Dishwashing Machine

LEGEND

Electrical Connections	
Required when machine equipped with SINGLE POINT ELECTRICAL CONNECTION	
E1	Motors, controls AND 30kW booster heater – multiple knockouts provided, 63-3/4" AFF.
Required when machine equipped with DUAL POINT ELECTRICAL CONNECTION	
E2	Motors and controls – multiple knockouts provided, 63-3/4" AFF.
E3	Internal 30kW booster heater – multiple knockouts provided, 63-3/4" AFF.
Multiple knockouts provided for 2", 1" and 1/2" trade size conduits.	
Plumbing Connections	
P1	Drain. May be drained to either side of valve, plug opposite side 2" FPT. Recommend a floor drain minimum of 12" from machine for access and maintenance. 7-3/8" AFF.
P2	Hot water. 1/2" FPT connection. 1/2", 11-3/16" AFF. See plumbing notes for required temperatures.
P3	Optional cold water connection for drain water tempering 1/2" FPT, cold water temperature 80°F, maximum 7-3/8" AFF.
Gas Connections (Natural Gas P4 or L.P. P5)	
P4	Gas connection – natural, 1/2" FPT, 10-3/4" AFF; 3.5" minimum, 7" maximum W.C. incoming.
P5	Gas connection – L.P., 1/2" FPT, 10-3/4" AFF; 8" minimum, 11" maximum W.C. incoming.
Vent Connections	
V1	Optional vent hoods, 4" x 16" vent stack with damper.

SPECIFICATIONS

Capacities

Racks Per Hour (NSF rated)	202
Wash Tank (U.S. gallons)	23
Conveyor Speed (feet per minute)	5.6

Motor Horsepower

Drive	1/6
Wash	2

Water Consumption

U.S. Gallons per Hour (maximum use at 20 PSI)	126
U.S. Gallons per Rack	0.62
Peak Drain Flow (U.S. gallons per minute)	38

Heating

Tank Heat, LP or Natural Gas (BTU per hour)	78,000
Optional Electric Booster (built-in) (kW for 40°F rise)	15
Optional Electric Booster (built-in) (kW for 70°F rise)	30

Venting

Load End (minimum CFM)	200
Unload End (minimum CFM)	400
(Gas exhaust venting must be installed according to local code)	

Shipping Weight (approximate) 594 lbs.

Crated Dimensions 53"L x 38"W x 78"H

E1	Single Point Electrical Connection with internal 30 kW Booster Heater		
Voltage	(E1) Motors, Controls and 30kW Booster Heater		Single Point Service Connection
	Rated Amps	Minimum Supply Circuit Ampacity / Maximum Protective Device	
208/60/3	94.6	110	Field Installed SGLPT-KIT2-CLE required, order separately
240/60/3	90.9	110	Field Installed SGLPT-KIT2-CLE required, order separately

E2	Dual Point Electrical Connection with Internal 30 kW Booster Heater				
E3	(For machines without internal booster heater, refer to E2, Motors & Controls connection only)				
Voltage	(E2) Motors and Controls		(E3) 30kW Booster Heater		Dual Point Service Connection
	Rated Amps	Minimum Supply Circuit Ampacity / Maximum Protective Device	Rated Amps	Minimum Supply Circuit Ampacity / Maximum Protective Device	
208/60/3	10.7	15	83.9	90	Dual Point Ships Standard
240/60/3	10.7	15	80.2	90	Dual Point Ships Standard



CL44eN-BAS GAS

High Temperature Rack Conveyor Dishwashing Machine

WARNING: Plumbing and electrical connections should be made by qualified personnel who will observe all the applicable plumbing, sanitary, safety codes and National Electrical Code.

WARNING: Gas heat machines must be provided with a means to exhaust the flue gases to the exterior of the building.

Plumbing Notes: Minimum incoming water temperatures: 110°F for 30kW internal booster, 140°F for 15kW field converted internal booster, 180°F without internal booster. Building flowing water pressure to dish machine is 20 PSI, (+/- 5 PSI). For non-booster machines, a PRV with internal expansion bypass is required. When ordered as an accessory, ½" brass regulator must be installed before the booster. Water temperature to the regulator must not exceed 140°F.

Recommended water hardness to be 3 grains or less for best results.

If gas pressure is higher than 7" (Natural) or 11" (LP) W.C., a pressure regulating valve must be installed (by others) in the gas line to the dish machine.

Electrical Note: Dishmachine not provided with internal GFCI protection.

CL44eN-BAS Gas Heat Dissipation		
Booster	BTU/HR.	
	Latent	Sensible
Without Booster	21,800	9,300
15kW Booster	35,400	15,200
30kW Booster	48,900	21,000

NOTE: 30kW Booster Heater field convertible to 15kW when 140°F incoming water provided. (Conversion instructions located in machine control box. Contact factory for 15kW booster amperage ratings.)

NOTE: Additional CLeN Voltages and Amperages are available, see document F40972.

VENT HOOD OPTIONS (Adjustable, vent stack can be adjusted 1" to either side)

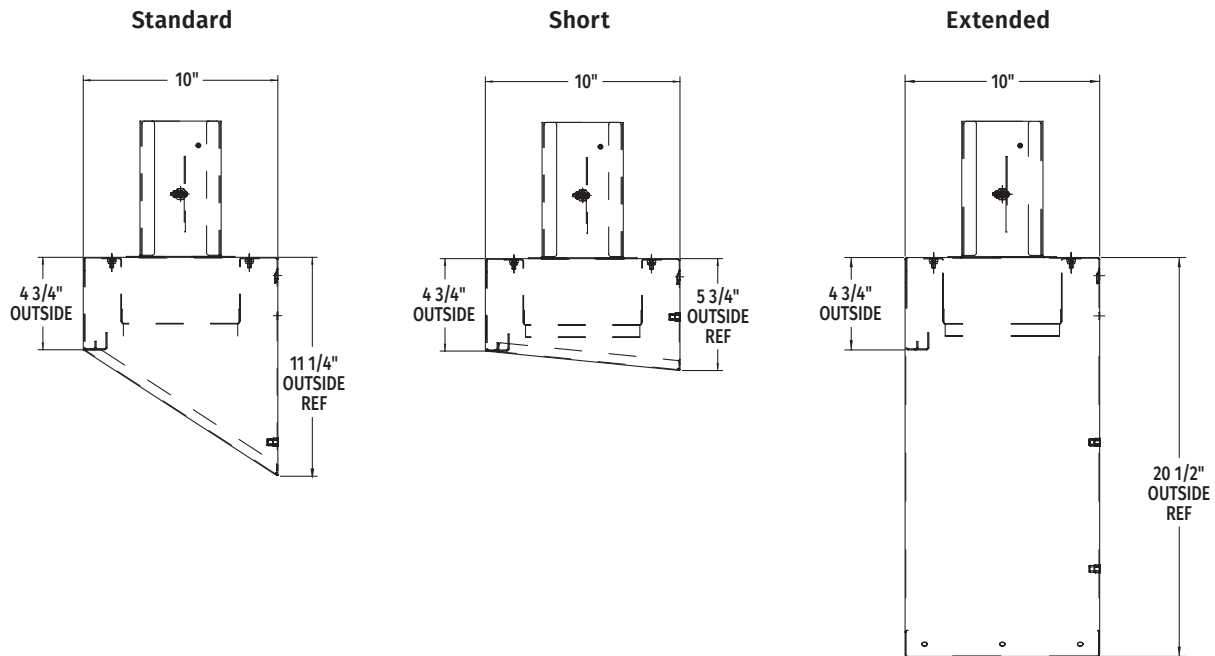

As continued product improvement is a policy of Hobart, specifications are subject to change without notice.