

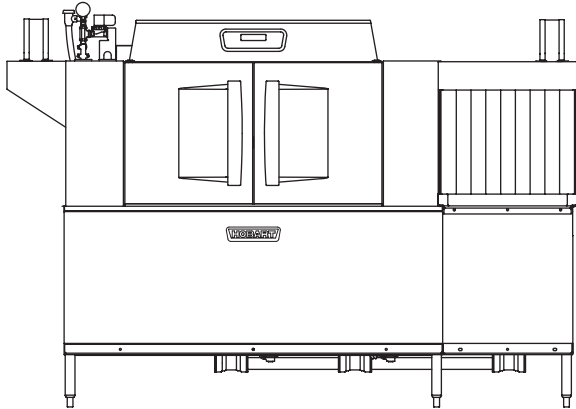

Project _____
 AIA # _____ SIS # _____
 Item # _____ Quantity _____ C.S.I. Section 114000



CLCS86eN-EGR STEAM High Temperature Rack Conveyor Dishwashing Machine



SPECIFIER STATEMENT

Specified dishwasher will be Hobart CLCS86eN Energy Recovery steam tank heat model with drain water energy recovery (DWER), corner scrapper and Opti-Rinse™. Includes 342 racks per hour capacity, 22" power scrapper, insulated ergonomic cabinet style doors, dirty water indicator, configurable "intelligent" de-lime notification, top mounted computer controls, and NSF approved pot and pan cycle mode. The wash tank utilizes durable precision pressure sensor monitors in lieu of conventional mechanical floats.

STANDARD FEATURES

- + 342 racks per hour
- + Internal stainless steel pressure-less 30 kW booster heater
 - and 240/60/3 voltage machines, when equipped with internal electric booster; single point kits available (see page 3)
 - Single point connection standard on 480/60/3 voltage machines, when equipped with internal electric booster
- + Drain water energy recovery (DWER)
- + 22" power scrapper plus separate wash and rinse tanks
- + Opti-Rinse™ system
- + Rapid return conveyor drive mechanism
- + Large double door opening for ease of cleaning
- + Doors are insulated & hinged with door interlock switches
- + 19.5" chamber height opening
- + Top mounted micro-processor control module
- + Energy saver mode (programmable auto-shut down)
- + Dirty water indicator
- + Manager activated low temperature alert
- + NSF rated configurable pot and pan dwell mode
- + Configurable "intelligent" de-lime notification
- + Service diagnostics
- + Self-aligning wash manifolds
- + Stainless steel anti-clogging wash arms
- + Internal stainless steel pressure-less 30 kW booster heater
- + Removable pump intake screen
- + Stainless steel self-draining pump and impeller
- + Single, sloping scrap screen and deep scrap basket
- + Stainless panels enclose perimeter and bottom
- + Door actuated drain closure
- + Drain water tempering kit
- + Vent fan control
- + Booster heater control

OPTIONS & ACCESSORIES (Available at extra cost)

- Standard, short, and extended stainless steel vent hoods
- Direct drive unloader – adds 38" length. Reference spec F39520 for more details
- Blower-dryer – adds 33¾" to length. Reference spec F40252 for more details (ships separate from dishmachine, contact Hobart Service for installation)
- Flanged feet kit (requires two kits)
- Higher than standard chamber (24" opening)
- Table limit switch with 10' wire
- Correctional package (contact Hobart for details)
- Pressure regulator valve (PRV), for use with external booster
- Water shock absorber kit
- Factory-mounted circuit breakers (contact Hobart for details)
- Field installed single point kits available for 208/60/3 and 240/60/3 machines when equipped with internal booster

CLEAN SERIES – CLCS86eN-EGR STEAM

Approved by _____ Date _____ Approved by _____ Date _____



CLCS86eN-EGR STEAM

High Temperature Rack Conveyor Dishwashing Machine

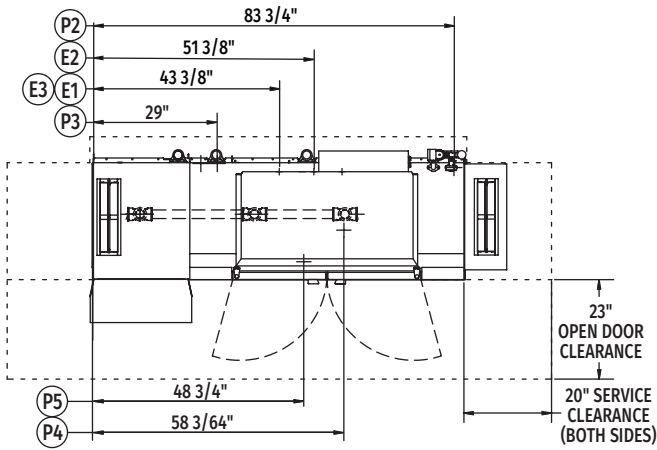

Top View Left to Right

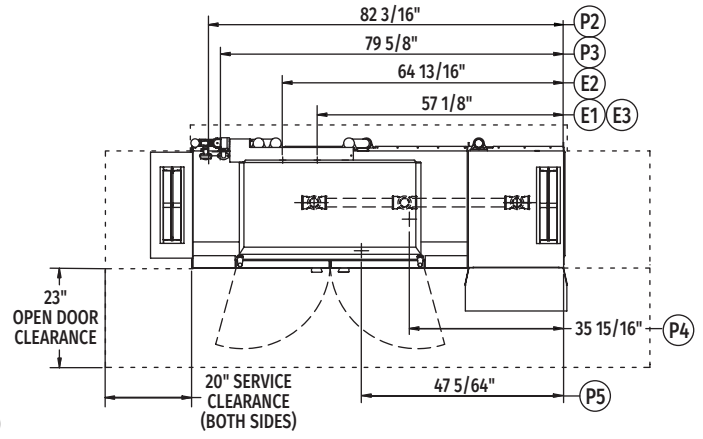

Top View Right to Left

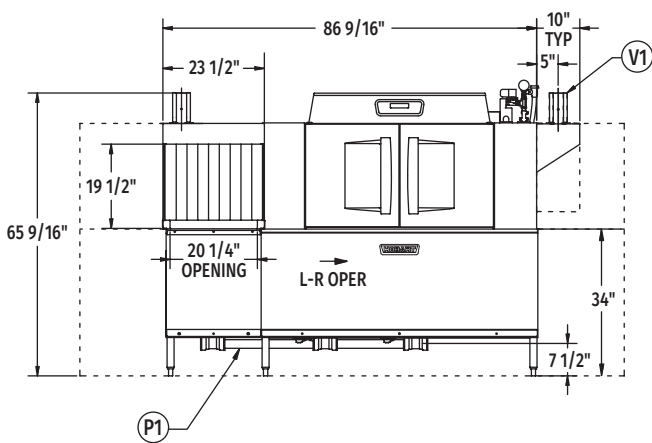

Front View Left to Right

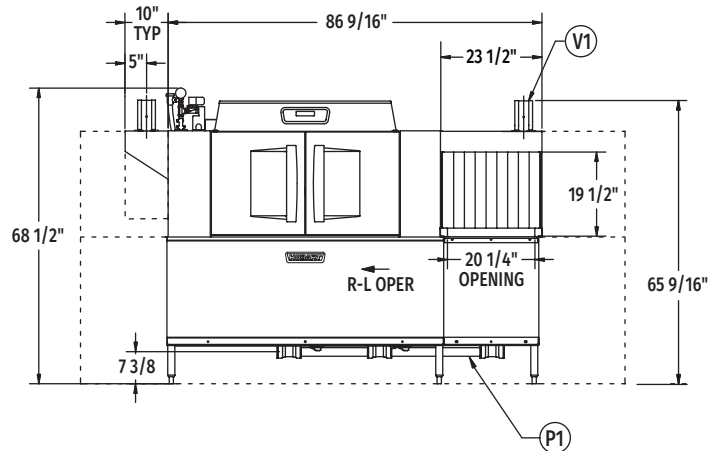

Front View Right to Left

VENT HOOD OPTIONS

(Adjustable, vent stack can be adjusted 1" to either side)

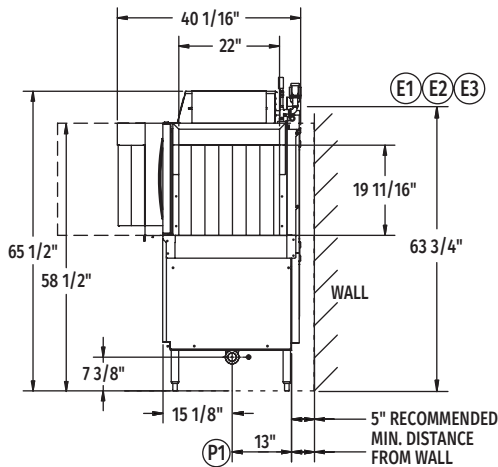

Side View

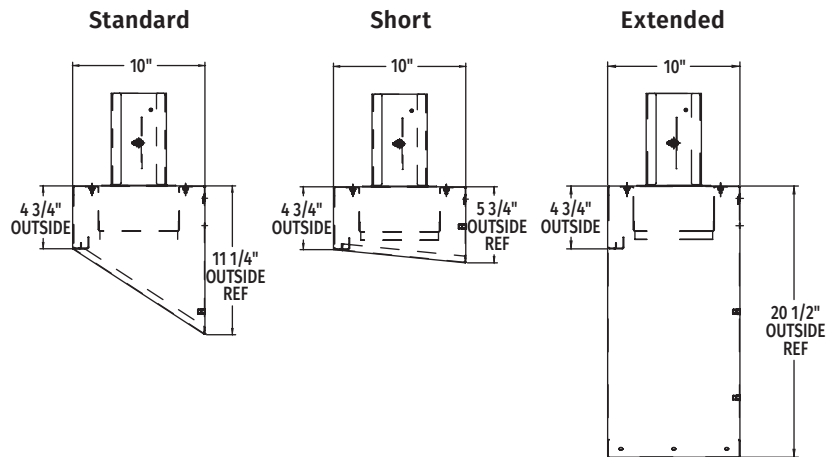

Reference page 4
for installation drawings

MODEL: CLPS86eN ENERGY RECOVERY
L-R OPERATION
D-974811
REV B

MODEL: CLPS86eN ENERGY RECOVERY
R-L OPERATION
D-974811
REV B



CLCS86eN-EGR STEAM

High Temperature Rack Conveyor Dishwashing Machine

LEGEND

Electrical Connections	
Required when machine equipped with SINGLE POINT ELECTRICAL CONNECTION	
E1	Motors, controls AND 30kW booster heater – multiple knockouts provided, 63-3/4" AFF.
Required when machine equipped with DUAL POINT ELECTRICAL CONNECTION	
E2	Motors and controls – multiple knockouts provided, 63-3/4" AFF.
E3	Internal 30kW booster heater – multiple knockouts provided, 63-3/4" AFF.
Multiple knockouts provided for 2", 1" and 1/2" trade size conduits.	
Plumbing Connections	
P1	Drain. May be drained to either side of valve, plug opposite side 2" FPT. Recommend a floor drain minimum of 12" from machine for access and maintenance. 7-3/8" AFF.
P2	Hot water. 1/2" FPT connection. 1/2", 11-3/16" AFF. See plumbing notes for required temperatures.
P3	Cold water connection 1/2" FPT, cold water temperature 80°F, maximum 7-3/8" AFF.
Steam Connections (P4 or P5)	
P4	Steam coils: 10 to 50 PSI flowing, 3/4" FPT, 11-18" AFF.
P5	Condensate return: A 10 PSI minimum differential pressure across the steam trap must be maintained. 3/4" FPT, 11-1/8" AFF one connection. (One bucket type trap furnished).
Vent Connections	
V1	Optional vent hoods, 4" x 16" vent stack with damper.

SPECIFICATIONS

Capacities

Racks per Hour (NSF rated)	342
Wash Tank (U.S. gallons)	23
Rinse Tank (U.S. gallons)	22
Power Scrapper (U.S. gallons)	23
Conveyor Speed (feet per minute)	9.5

Motor Horsepower

Drive	1/6
Wash	2
Power Scrapper	2
Rinse	2

Water Consumption

U.S. Gallons per Hour (maximum use at 20 PSI)	132
U.S. Gallons per Rack	0.39
Peak Drain Flow (U.S. gallons per minute)	38

Heating

Tank Heat, steam coils (pounds per hour)	130
Electric Booster (built-in) (kW for 70°F rise)	30
Steam Booster (external) (pounds per hour)	63
(If used on 20 PSI steam, 20 PSI water flowing, 130°F entering water raised to 180°F minimum)	

Venting

Load End (minimum CFM)	200
Unload End (minimum CFM)	400

Shipping Weight (approximate) 1,040 lbs.

Crated Dimensions 96"L x 38"W x 78"H

E1	Single Point Electrical Connection with internal 30 kW Booster Heater		
Voltage	(E1) Motors and Controls 30kW Booster Heater		Single Point Service Connection
	Rated Amps	Minimum Supply Circuit Ampacity / Maximum Protective Device	
208/60/3	108.0	125	Field Installed SGLPT-KIT2-CLE required, order separately
240/60/3	104.3	125	Field Installed SGLPT-KIT2-CLE required, order separately
480/60/3	53.2	70	Ships Standard, Factory Installed

E2	Dual Point Electrical Connection with Internal 30 kW Booster Heater				
Voltage	(E2) Motors and Controls		(E3) 30kW Booster Heater		Dual Point Service Connection
	Rated Amps	Minimum Supply Circuit Ampacity / Maximum Protective Device	Rated Amps	Minimum Supply Circuit Ampacity / Maximum Protective Device	
208/60/3	24.1	35	83.9	90	Dual Point Ships Standard
240/60/3	24.1	35	80.2	90	Dual Point Ships Standard
480/60/3	13.1	20	40.1	50	Field Convertible



CLCS86eN-EGR STEAM

High Temperature Rack Conveyor

Dishwashing Machine

WARNING: Plumbing and electrical connections should be made by qualified personnel who will observe all the applicable plumbing, sanitary, safety codes and National Electrical Code.

Plumbing Notes: Minimum incoming water temperatures: 110°F for 30kW internal booster. Building flowing water pressure to dish machine is 20 PSI (+/- 5 PSI).

Single cold water connection supplies both drain water energy recovery and drain water tempering.

Recommended water hardness to be 3 grains or less for best results.

Steam Heat Only: Flowing steam pressures above 50 PSI must have a pressure regulator (by others) installed in the steam line.

Shut off valve must be supplied (by others) in the steam line to the dish machine.

Electrical Note: Dishmachine not provided with internal GFCI protection.

CLCS86eN-EGR Steam Heat Dissipation	
BTU/HR.	
Latent	Sensible
64,000	27,400

NOTE: Additional ClEN Voltages and Amperages are available, see document F40972.

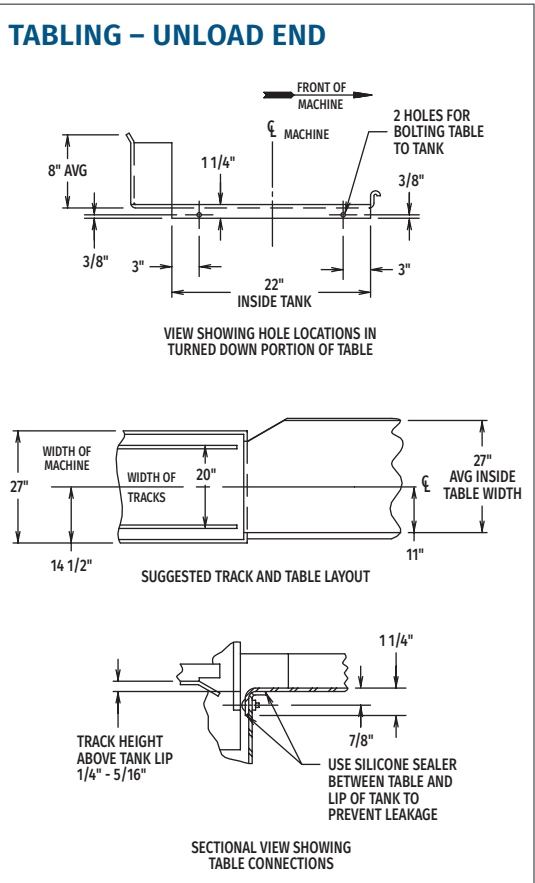
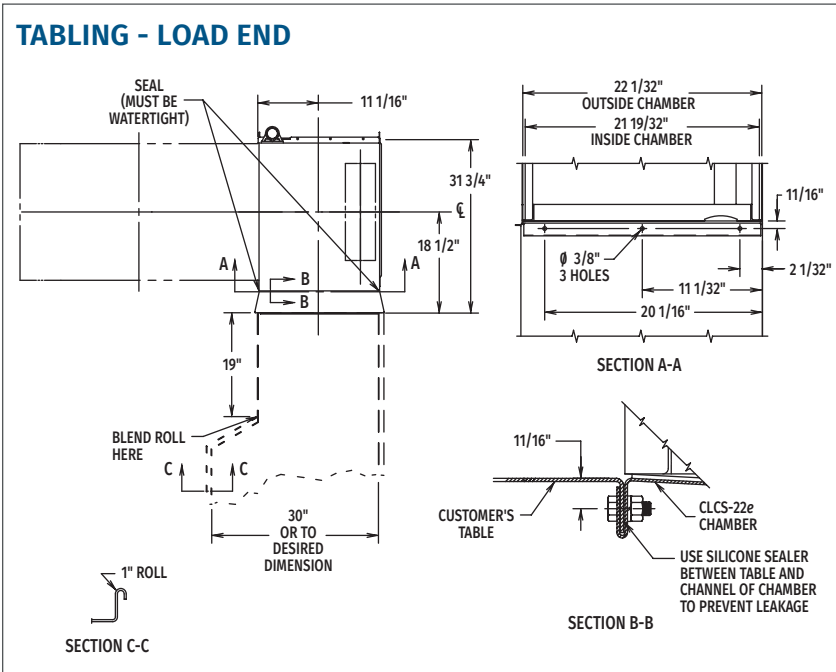

As continued product improvement is a policy of Hobart, specifications are subject to change without notice.