

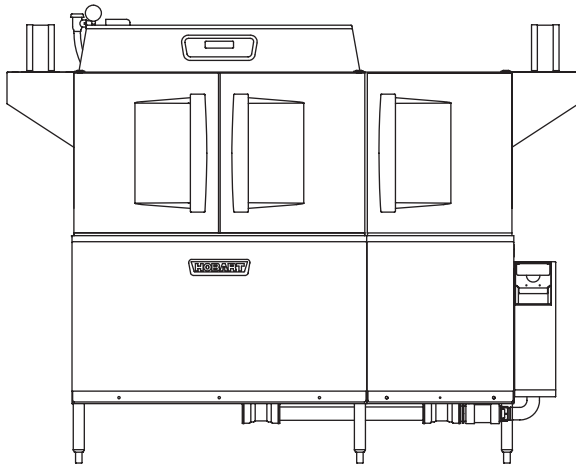

Project _____
 AIA # _____ SIS # _____
 Item # _____ Quantity _____ C.S.I. Section 114000



CLPS66eN-ADV *advansys* ELECTRIC High Temperature Rack Conveyor Dishwashing Machine



STANDARD FEATURES

- + 202 racks per hour
- + 22" power scrapper
- + Drain water energy recovery (DWER)
- + Automatic soil removal (ASR)
- + Opti-Rinse™ system
- + Drain water tempering kit
- + Rapid return conveyor drive mechanism
- + Internal stainless steel pressure-less 30 KW booster heater
 - Dual point electrical connection standard on 208/60/3 and 240/60/3 voltage machines; single point kits available (see page 3)
 - Single point connection standard on 480/60/3 and 600/60/3 voltage machines
- + Large double door opening for ease of cleaning
- + Doors are insulated & hinged with door interlock switches
- + 19.5" chamber height opening (accepts sheet pans)
- + Top mounted micro-processor control module
- + Energy saver mode (programmable auto-shut down)
- + Dirty water indicator
- + Manager activated low temperature alert
- + NSF rated configurable pot and pan dwell mode
- + Configurable "intelligent" delime notification
- + Service diagnostics
- + Self-aligning wash manifolds
- + Stainless steel anti-clogging wash arms
- + Removable pump intake screen
- + Stainless steel self-draining pump and impeller
- + Single, sloping scrap screen and deep scrap basket
- + Stainless panels enclose perimeter and bottom
- + Door actuated drain closure
- + Vent fan control
- + Booster heater control
- + Power scrapper vent cowl curtain kit
- + ENERGY STAR® Certified



SPECIFIER STATEMENT

Specified dishwasher will be Hobart CLPS66eN Advansys electric tank heat model with drain water energy recovery (DWER), automatic soil removal (ASR) and Opti-Rinse™. Includes 22" power scrapper, insulated ergonomic cabinet style doors, dirty water indicator, configurable "intelligent" de-lime notification, top mounted computer controls, and NSF approved pot and pan cycle mode. The wash tank utilizes durable precision pressure sensor monitors in lieu of conventional mechanical floats. The 19.5" standard chamber height will accommodate up to (6) standard sheet pans at a time on an open-end sheet pan rack.

OPTIONS & ACCESSORIES (Available at extra cost)

- Standard, short, and extended stainless steel vent hoods
- Direct drive unloader – adds 38" length. Reference spec F39520 for more details
- Side loader – SL23 adds 23" length, SL30 adds 30" length. Reference specs F40926 and F40927 for more details
- Blower-dryer – adds 33 3/8" to length. Reference spec F40252 for more details (ships separate from dishmachine, contact Hobart Service for installation)
- Flanged feet kit (requires two kits)
- Higher than standard chamber (24" opening)
- Table limit switch with 10' wire
- Correctional package (contact Hobart for details)
- Pressure regulator valve (PRV), for use with external booster
- Water shock absorber kit
- Factory-mounted circuit breakers (contact Hobart for details)
- Field installed single point kits available for 208/60/3 and 240/60/3 machines when equipped with internal booster

CLEAN SERIES – CLPS66eN-ADV *advansys* ELECTRIC

Approved by _____ Date _____ Approved by _____ Date _____



CLPS66eN-ADV advansys ELECTRIC

High Temperature Rack Conveyor Dishwashing Machine

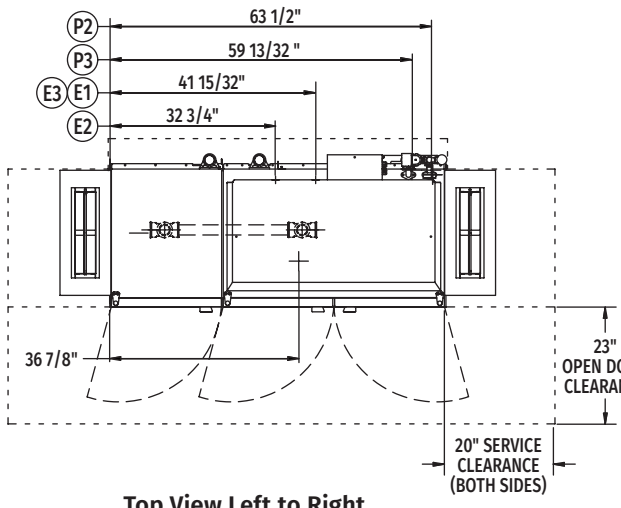

Top View Left to Right

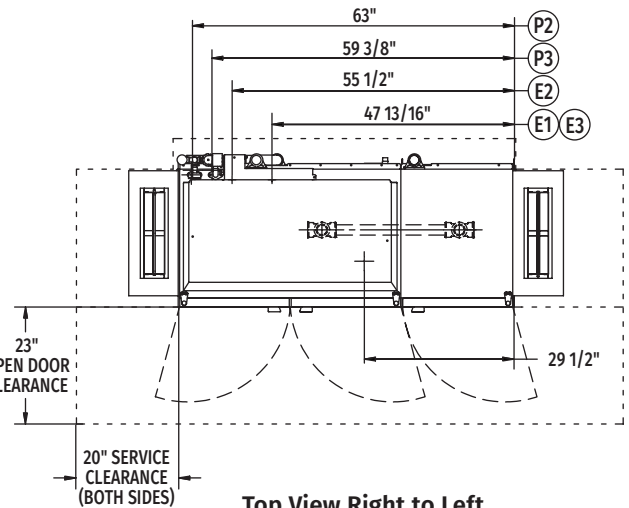

Top View Right to Left

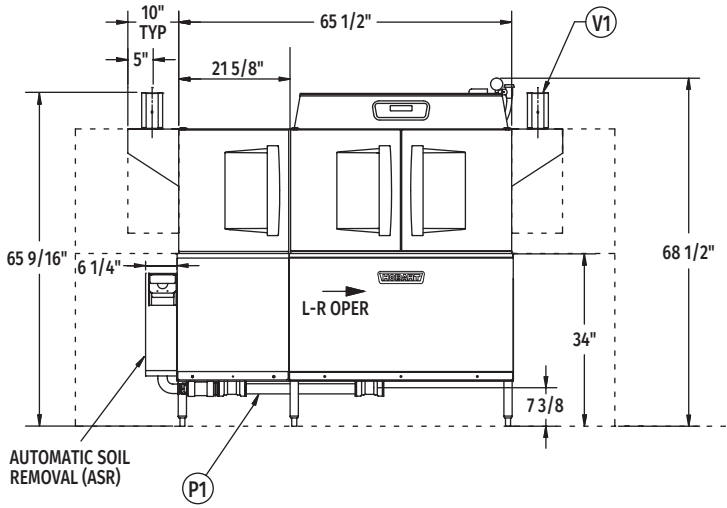

Front View Left to Right

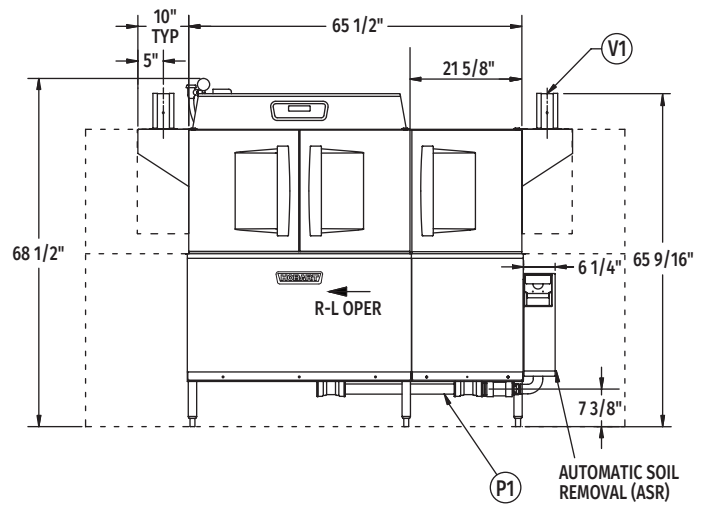

Front View Right to Left

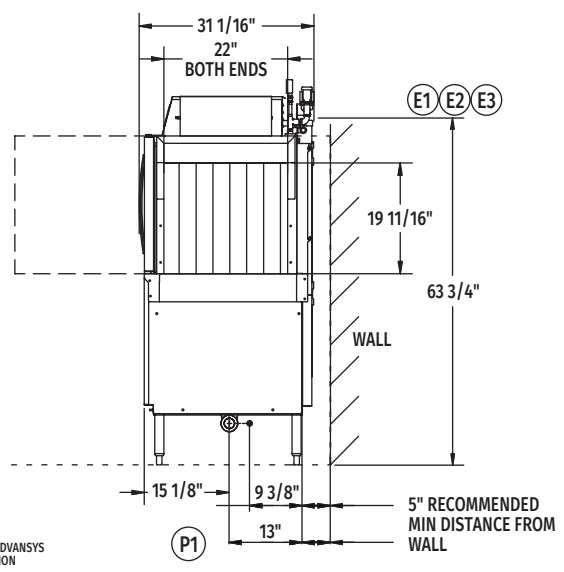

Side View

Tabling Connection: 66" inside tank (at table connection)

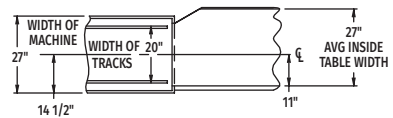

Suggested Track and Table Layout

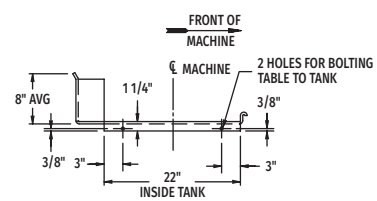

View Showing Hole Locations in Turned Down Portion of Table

MODEL: CLPS66eN ADVANSYS
L-R OPERATION
D-974807
REV B

MODEL: CLPS66eN ADVANSYS
R-L OPERATION
D-974806
REV B



CLPS66eN-ADV advansys ELECTRIC

High Temperature Rack Conveyor Dishwashing Machine

LEGEND

Electrical Connections	
Required when machine equipped with SINGLE POINT ELECTRICAL CONNECTION	
E1	Tank heat, motors, controls AND 30kW booster heater – multiple knockouts provided, 63-3/4" AFF.
Required when machine equipped with DUAL POINT ELECTRICAL CONNECTION	
E2	Tank heat, motors and controls – multiple knockouts provided, 63-3/4" AFF.
E3	Internal 30kW booster heater – multiple knockouts provided, 63-3/4" AFF.
Multiple knockouts provided for 2", 1" and 1/2" trade size conduits.	
Plumbing Connections	
P1	Drain. May be drained to either side of valve, plug opposite side 2" FPT. Recommend a floor drain minimum of 12" from machine for access and maintenance. 7-3/8" AFF.
P2	Hot water. 1/2" FPT connection. 1/2", 11-3/16" AFF. See plumbing notes for required temperatures.
P3	Cold water connection 1/2" FPT, cold water temperature 80°F, maximum 7-3/8" AFF.
Vent Connections	
V1	Optional vent hoods, 4" x 16" vent stack with damper.

SPECIFICATIONS

Capacities

Racks per Hour (NSF rated)	202
Wash Tank (U.S. gallons)	23
Power Scrapper (U.S. gallons)	23
Conveyor Speed (feet per minute)	5.6

Motor Horsepower

Drive	1/6
Wash	2
Power Scrapper	2
ASR	1/2

Water Consumption

U.S. Gallons per Hour (maximum use at 20 PSI)	126
U.S. Gallons per Rack	0.62
Peak Drain Flow (U.S. gallons per minute)	38

Heating

Tank Heat, Electric (kW)	15
Electric Booster (built-in) (kW for 70°F rise)	30

Venting

Load End (minimum CFM)	200
Unload End (minimum CFM)	400

Shipping Weight (approximate) 942 lbs.

Crated Dimensions 76"L x 38"W x 78"H

E1	Single Point Electrical Connection with internal 30 kW Booster Heater		
Voltage	(E1) Tank Heat, Motors, Controls 30kW Booster Heater		Single Point Service Connection
	Rated Amps	Minimum Supply Circuit Ampacity / Maximum Protective Device	
208/60/3	145.0	175	Field Installed SGLPT-KIT4-CLE required, order separately
240/60/3	138.2	150	Field Installed SGLPT-KIT2-CLE required, order separately
480/60/3	70.7	90	Ships Standard, Factory Installed
600/60/3	49.4	75	Ships Standard, Factory Installed

E2	Dual Point Electrical Connection with Internal 30 kW Booster Heater				
Voltage	(E2) Tank Heat, Motors, Controls		(E3) 30kW Booster Heater		Dual Point Service Connection
	Rated Amps	Minimum Supply Circuit Ampacity / Maximum Protective Device	Rated Amps	Minimum Supply Circuit Ampacity / Maximum Protective Device	
208/60/3	60.6	80	83.9	90	Dual Point Ships Standard
240/60/3	58.0	80	80.2	90	Dual Point Ships Standard
480/60/3	30.6	40	40.1	50	Field Convertible
600/60/3	22.6	35	26.9	40	Field Convertible



CLPS66eN-ADV *advansys* ELECTRIC

High Temperature Rack Conveyor Dishwashing Machine

WARNING: Plumbing and electrical connections should be made by qualified personnel who will observe all the applicable plumbing, sanitary, safety codes and National Electrical Code.

Plumbing Notes: Minimum incoming water temperatures: 110°F for 30kW internal booster. Building flowing water pressure to dish machine is 20 PSI, (+/- 5 PSI).

Single cold water connection supplies both drain water energy recovery and drain water tempering.

Recommended water hardness to be 3 grains or less for best results.

Electrical Note: Dishmachine not provided with internal GFCI protection.

CPS66eN-ADV Electric Heat Dissipation	
BTU/HR.	
Latent	Sensible
43,200	18,500

NOTE: Additional CLeN Voltages and Amperages are available, see document F40972.

VENT HOOD OPTIONS (Adjustable, vent stack can be adjusted 1" to either side)

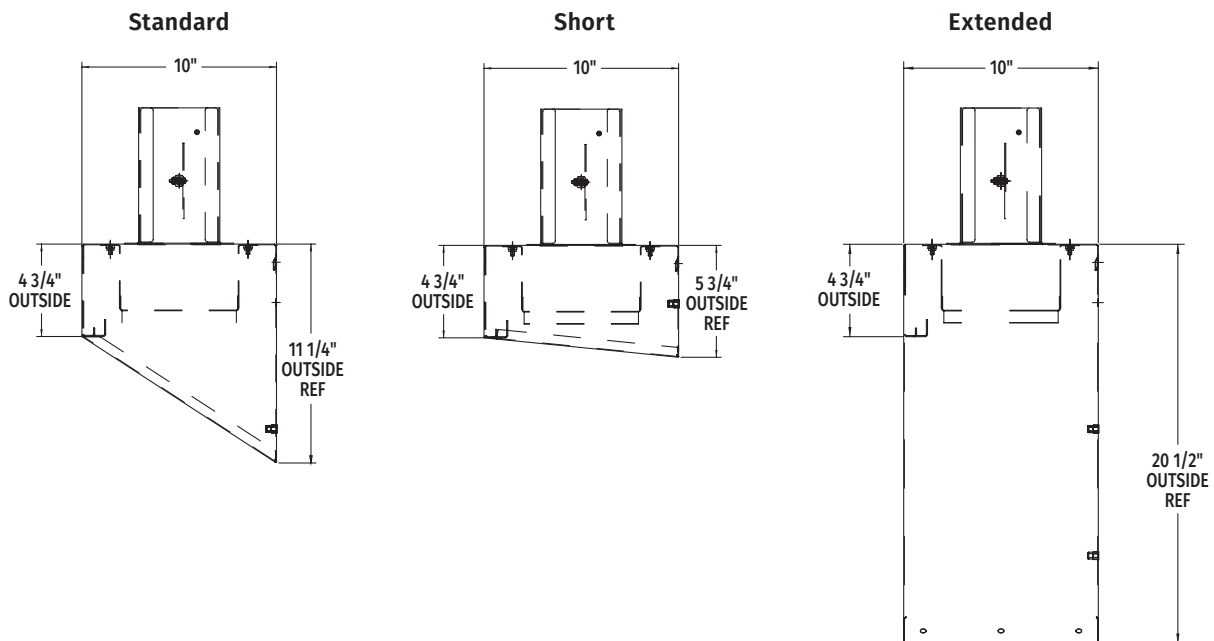

As continued product improvement is a policy of Hobart, specifications are subject to change without notice.