



Project _____
 AIA # _____ SIS # _____
 Item # _____ Quantity _____ C.S.I. Section 114000



HBR302-1 Bench/Receiving Digital Scale



SPECIFIER STATEMENT

The HBR302-1 is an industrial scale, commonly used as a receiving scale, for a variety of applications due to its flexibility.

MODEL

- HBR302-1** 300 lb. capacity (150 kg)

STANDARD FEATURES

- + Easy-to-read display
- + Legal for trade
- + Rechargeable battery or AC adaptor
- + Energy saver setting – set shutoff time to extend battery life
- + Low battery indicator
- + Check weighing with over/under blue LED indicator
- + Batch weighing
- + Tilt and rotatable display for easy viewing
- + Toggle between (lb./kg.)
- + Stainless steel
- + Tare indicator
- + One touch and reset tare
- + Stable weight indicator
- + Net/gross weighing
- + Automatic zero tracking
- + Leveling leg set
- + Leveling indicator

ACCESSORIES

- HBR300-STAND – Moveable cart with swivel casters, rear locks

HBR302 SCALE APPLICATIONS

- + Batch Weighing
- + Check Weighing
- + Parcel Shipping/Receiving
- + Quality Control
- + Counting
- + General Bulk Weighing

HBR302-1 BENCH/RECEIVING DIGITAL SCALE

Approved by _____ Date _____ Approved by _____ Date _____

SPECIFICATIONS

- + **Dimensions: Shipping:** 33"L x 19"W x 14"H;
Assembled: 29.4"H x 25"L x 13.875"W
- + **Platter:** 13.781"W x 19.6875"L stainless platter
- + **Display:** 90 degree rotating LCD display

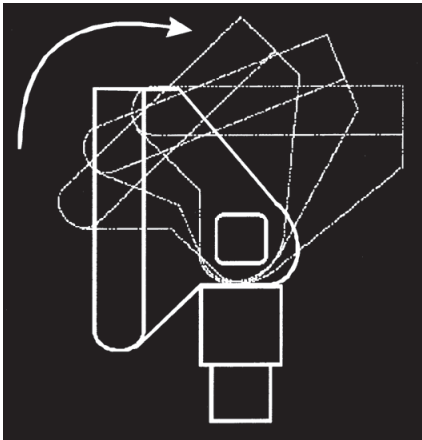

ROTATING DISPLAY

- + **Characters and Size:** 1.3" x 0.7" (32mm x 17mm), 5 digits
- + **Shipping Weight:** 50 lbs.

- + **Power Supply:** 120/60/1 using AC adaptor (included as standard) or rechargeable battery (must be purchased separately). Battery life 240 hours, 12 hour charging time
- + **Operating Temp:** 14°F to 104°F (-10°C to 40°C)
- + **Operating Humidity:** 30% to 85% RH
- + **Waterproof Classification:** IP52 (IP50 when connected to AC adaptor)

SELLING FEATURES

- + The HBR302-1 can be used on the bench, floor or moveable cart
- + Receiving scales prevent costly mistakes by accurately check weighing
- + The HBR302-1 can be used as a bench portion control scale to keep food costs in line
- + The scale tare feature can be set for package or bowl weight to protect profits
- + Easy to clean and sanitize

Model	Capacity (lb.)	Capacity (oz.)	Capacity (kg)
HBR302-1	300 x 0.1	4800 x 2	150 x 0.05

DETAILS AND DIMENSIONS

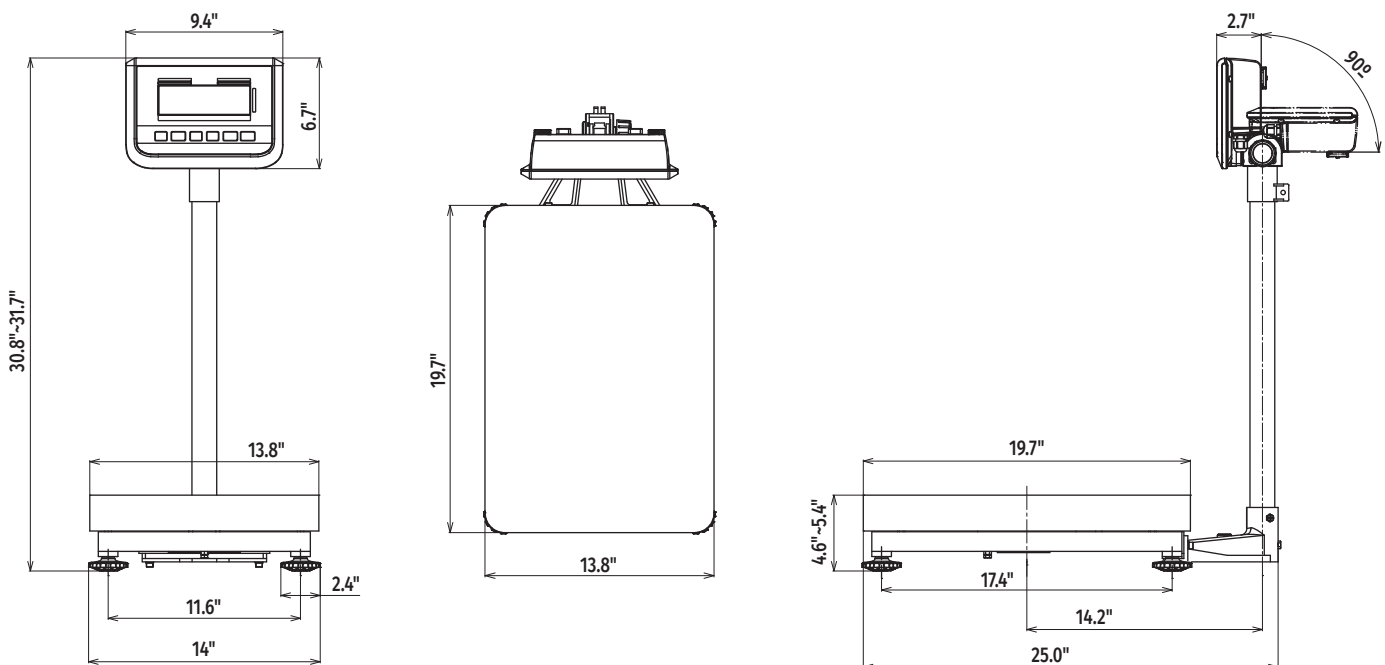



DETAILS AND DIMENSIONS

Optional Cart: HBR300-STAND

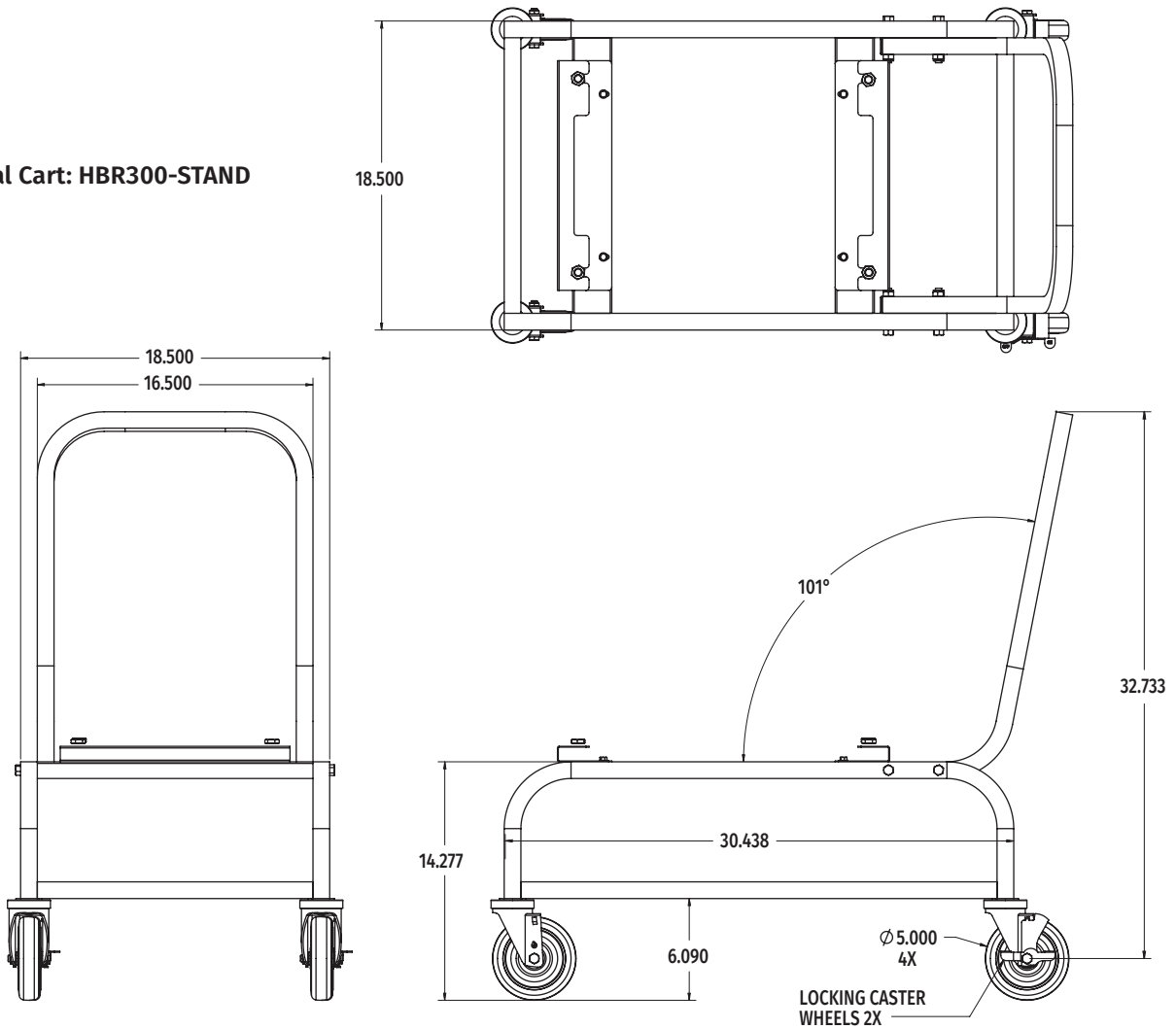

As continued product improvement is a policy of Hobart, specifications are subject to change without notice.