



Project _____
 AIA # _____ SIS # _____
 Item # _____ Quantity _____ C.S.I. Section 114000



HCM61 Bowl-Style Food Processor



MODEL

HCM61 Bowl-Style Food Processor

STANDARD FEATURES

- + 1.5 HP direct drive motor
- + Patented bowl scraper with integrated lid wiping system
- + Durable Xylex cover with bowl gasket
- + Hobart COOLCUTTER knives
- + Triple interlock system
- + User friendly controls
- + Compact design
- + Anodized aluminum base with powder coated top cover

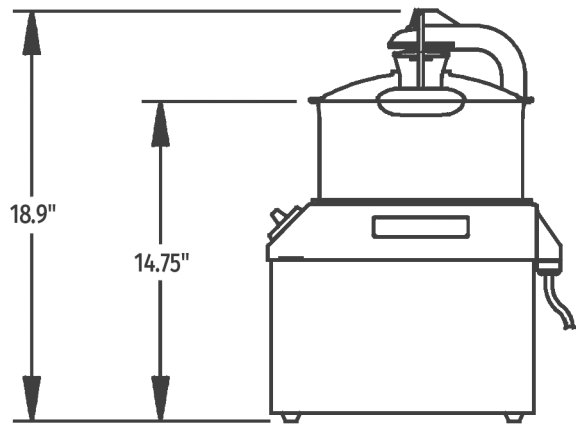

SPECIFIER STATEMENT

Specified unit will be an NSF rated, 6-quart, single speed Hobart bowl-style food processor with user-friendly controls and a compact design. Food processor has a patented bowl scraper with integrated lid wiping system, a durable Xylex cover with bowl gasket, triple interlock system, and an anodized aluminum base with powder coated top cover. Hobart COOLCUTTER knives cut through more product in less time and are ideal for emulsifying and pureeing foods.

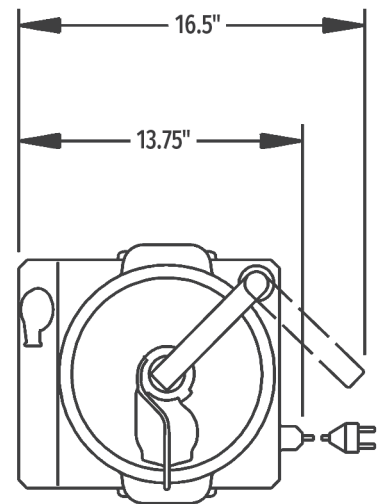
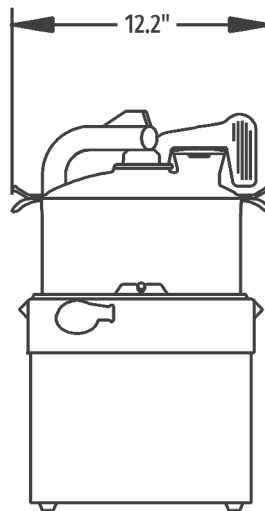

[CAD and/or Revit Files Available](#)

HCM61 BOWL-STYLE FOOD PROCESSOR

Approved by _____ Date _____ Approved by _____ Date _____



SOLUTIONS / BENEFITS

PERFORMANCE

1.5 HP Direct-Drive Motor

- + Prevents stalling and slipping

COOLCUTTER Knives

- + Hobart exclusive knives increase productivity and product consistency while minimizing product temperature rise
- + Two stainless steel serrated knives and two stainless steel turning knives force product into cutting knives resulting in reduced processing time

1725 RPM Knife Speed

- + Ideal speed for emulsifying and pureeing foods

Compact Design

- + Occupies minimal counter space
- + Handles are molded on both sides of housing to move unit easily

EASE OF USE

Xylex Cover with Bowl Gasket

- + See-through design allows continuous view of product
- + Large tube feed makes it easier to add ingredients

User Friendly Controls

- + Controls include ON, OFF and PULSE setting

Patented Bowl Scraper with Integrated Lid Wiping System

- + Bowl scraper helps with temperature control
- + Integrated lid wipers provide easy viewing of product during processing

SANITATION & CLEANING

Anodized Aluminum Base with Powder Coated Top Cover

- + Rubber feet on base prevents movement
- + Easy clean up and durable finish

OPERATOR ASSURANCE

Triple Interlock System

- + Three interlocks prevent operation unless:
 1. Bowl is in place
 2. Bowl cover is in place
 3. Lid lock arm is in place

SPECIFICATIONS

Electrical: 120/60/1, 3 conductor power cord (12 AWG) is 8 feet in length with NEMA5-20P plug. 15.4 rated amps.

Motor: 1.5 HP

Switches: ON, OFF, and PULSE switch

Footprint: 12" W x 18.5" H x 13.5" D (16" D with safety arm swing)

Warranty: Unit has full one-year warranty on parts, labor and mileage against manufacturer's defects. Service contracts are available.

Weight: Net 60 lb., shipping 62 lb.

Plugs and Receptacles:

Machine Voltages	
Service Current Requirement if Plug Connected	120/60/1
	15 Amp.
Terminal Designation of Plug	2 Pole 3 Wire Grounding
NEMA Plug Configuration	5-20P
Plug Configuration	
Molded Plug on Cord	Yes
Plug - Straight/Angle	Straight
NEMA Receptacle or Connector Configuration	5-15R

As continued product improvement is a policy of Hobart, specifications are subject to change without notice.