



Project _____
 AIA # _____ SIS # _____
 Item # _____ Quantity _____ C.S.I. Section 114000



HS SLICER SERIES – HS6-1PS

HS6-1PS Heavy-Duty Slicer



SPECIFIER STATEMENT

Specified unit will have an integrated scale with Smartslice technology which alerts user with flashing green eyelevel screen when the desired weight is met. The large touchscreen will contain speed keys and alert messages. The unit will provide a minimum 1/2 HP motor. The knife will be constructed of stainless steel with hardened cobalt edge for improved yield performance. The 13" knife will be removable with single handle tool - providing zero knife exposure during sharpening and cleaning. It will have a tilt and removable carriage as well as stainless steel knife cover. The unit will provide no-volt release, gauge-plate interlock, close-to-stop and carriage-system interlock, 30-second shut off and home-start interlocks.

MODELS

- HS6-1PS** Manual slicer with 10 lb. capacity scale

STANDARD FEATURES

KNIFE

- + 13" CleanCut™ knife
- + Removable ring guard cover
- + Zero knife exposure
- + Heavy-gauge stainless steel knife cover
- + Top-mounted Borazon stone sharpener

OPERATION

- + 1/2 H.P. knife drive motor
- + Manual slicer with integrated scale
- + Metric and customary options

INTERLOCKS

- + Close-to-stop
- + Home-start position
- + 30-second shut off
- + Gauge-plate interlock
- + Carriage-system interlock
- + No-volt release

HOUSING AND BASE

- + Burnished aluminum base
- + Machined grooves on gauge plate and knife cover
- + Exclusive tilting, removable carriage system
- + Electroless nickel plated single slide rod with reservoir wick in transport
- + Double-action indexing cam
- + Ergonomic-style handle
- + Rear-mounted, removable meat/vegetable grip arm
- + LCD touch screen display

ACCESSORIES (Available at extra cost)

- Full fence
- Food chute

Approved by _____ Date _____ Approved by _____ Date _____



SOLUTIONS / BENEFITS

PRECISION SLICING

13" CleanCut™ Knife

- + Super alloy edge stays sharp longer
- + Lasts two to three times longer than carbon coated or stainless steel knives

Top Mounted Borazon Stone Sharpener

- + Single-action sharpens and hones in just 15 seconds
- + Removable and warewasher safe for easy cleaning and sanitation – can be used wet or dry
- + Lifetime guaranteed Borazon sharpening stones provide maximum performance with reduced maintenance costs

Machined Grooves on Gauge Plate and Knife Cover

- + Reduces drag for smoother slicing motion

Double-Action Indexing Cam

- + The first full revolution of the indexing knob provides precise control of shaving, chipping and thin slicing
- + The second revolution opens the gauge plate quickly for thicker slicing
- + Gauge plate holds position for consistent, precision slicing

EASY TO USE

½ H.P. Knife Drive Motor

- + Reserve power runs at 430 rpm for optimum results

Electroless Nickel Plated Single Slide Rod with Reservoir Wick in Transport

- + Smooth operation with continuous lubrication of carriage rod

Zero Knife Exposure*

- + Knife edge is covered when sharpener is both mounted and removed, making cleaning easier
- + Gauge plate remains closed during operation of sharpener

Close to Stop

- + Closing of the gauge plate turns off the slicer

Gauge Plate Interlock

- + Gauge plate must be closed to remove carriage for cleaning and cannot be opened when removed

Carriage System Interlock

- + Will not tilt away or remove if gauge plate is not closed

30-Second Shut Off

- + Slicer will shut off after 30 seconds of inactivity

Home-Start Position

- + Slicer will not start unless carriage is in home position

No Volt Release

- + Slicer must be restarted if power fails or slicer is unplugged

Manual Slicer with Integrated 10 lb. Capacity Scale

- + Reduced labor, reduced footprint, increased profit, ease of use
- + Weighs portions during manual slicing operation
- + Scale built into slicer; no need for separate piece of equipment
- + Ensures portions
- + Conveniently located touch screen controls

LCD Touch Screen Display

- + Metric and customary options
- + Stack function; separates same repeated weight for faster portioning
- + Customizable “speed key” icons making it faster to repeat common tasks
- + Customizable alert messages alerting user to sharpen, clean, sanitize or lubricate slicer

EASY TO CLEAN

Removable Knife

- + Knife easily removes with patented removal tool
- + Area within ring guard is open for faster cleaning
- + Knife and tool are warewasher safe for easy cleaning and sanitation

Removable Ring Guard Cover*

- + Catches product debris around the knife for easy removal during cleaning
- + Reduces time to ‘floss’ during cleaning

Exclusive Tilting, Removable Carriage System*

- + Tilt design allows for ease of mid-day cleaning
- + Removable for complete cleaning and sanitation

Rear-Mounted, Removable Meat Grip

- + Opens up front of product tray for unobstructed loading
- + Removable meat grip allows for easy cleaning

Burnished Aluminum Base

- + Limited cracks/crevices or bolt holes where product can lodge and bacteria may grow

**Feature unique to Hobart*



SPECIFICATIONS

KNIFE

13" CleanCut Knife: The knife is approximately 13", constructed of 304L stainless steel and high performance Stellite alloy. Knife cover is retained magnetically, and is quickly removed by pulling straight back on the top cover knob.

Removable Knife Option: The patented knife removal tool covers the knife edge and safely removes knife from gauge plate to allow for thorough cleaning.

Removable Ring Guard Cover: Fits on top of ring guard to catch food debris. When removed, reveals a 0.12" space between knife and guard for easier flossing. Ring guard is made with Zytel™ plastic and can be washed in warewasher or three compartment sink.

Zero Knife Exposure: Knife edge is not exposed during cleaning or sharpening procedures.

Top Mounted Borazon Stone Sharpener: Single action operation utilizing two Borazon stones to sharpen and hone in five seconds. Removable, top mounted and warewasher safe. When sharpener is removed for cleaning, knife edge is completely shielded. Borazon stones have a lifetime guarantee.

MOTOR

Poly V-Belt Knife Drive System: Knife is driven by a Hobart Poly V belt and runs at 430 rpm for optimal performance.

½ H.P. Knife Drive Motor: ½ H.P. permanently lubricated ball bearings. Single phase capacitor-start, induction run.

INTERLOCKS

Close to Stop: After slicing, a quick turn of the index knob to the closed position turns off the slicer.

Gauge Plate Interlock: Gauge plate interlock protects knife edge when indicator is at zero.

Carriage System Interlock: Carriage will not tilt away or remove if gauge plate indicator is not closed.

No Volt Release: In the event of a power loss, slicer must be restarted before operation can continue.

30-Second Shut Off: Slicer will shut off after 30 seconds of inactivity.

Home-Start Position: Slicer will not start unless carriage is in home position.

HOUSING AND BASE

Sanitary Burnished Aluminum Base: One-piece base has fewer places to harbor soil and is easier to clean. Limits holes or crevices in which food can lodge.

Finish: Stainless steel top cover, burnished aluminum product tray and gauge plate.

Exclusive Tilting, Removable Carriage System: Aluminum product tray tilts easily for mid-day cleaning and is removable for thorough cleaning and sanitation procedures. The carriage has 12.5" manual travel.

Electroless Nickel Plated Single Slide Rod with Reservoir Wick in Transport: Transport slide rod is E-Nickel electroless plated. Slide rod bearings feature an oil reservoir/oil wick.

Double-Action Indexing Cam: A solid construction index knob moves the gauge plate via a barrel cam ensuring consistent slice thickness across machine and over time. First revolution of index cam for precision slicing; second revolution for thicker slicing selection.

Integrated 10 lb. Capacity Scale: Maximum capacity is 10 pounds in increments of 0.01 pounds or 0.1 oz. The LCD touchscreen is positioned for ease of use. Eye-level display. The keys include: MODE identifies weight or repeat last portion.

Removable Stainless Steel Platter: Stainless steel platter can be easily removed and cleaned in a dishwasher or 3 compartment sink.

Ergonomic Style Handle: Specially shaped and positioned for ease of use during manual operation.

Rear Mounted, Removable Meat Grip Arm: Rear mounted grip is high strength thermoplastic. Swings out of way when not in use.

Electrical Specification: 120/60/1; 5.6 Amps.

Switch: Moisture protected push button switch.

Cord & Plug: 6-foot, three-wire power supply cord and plug. Plug not furnished on export models.

Capacity: The carriage will take food up to 5¾" x 10¾" rectangle or 7.5" in diameter.

Gauge Plate: Gauge plate is a heavy aluminum extrusion with machined grooves for smooth feeding. Adjustable to cut any thickness of slice up to 1".

Warranty: All parts and service coverage for one year including knife. Lifetime guarantee on Borazon stones in the sharpening system.

Shipping Weight: 150 lbs.



HS6-1PS

Heavy-Duty Slicer

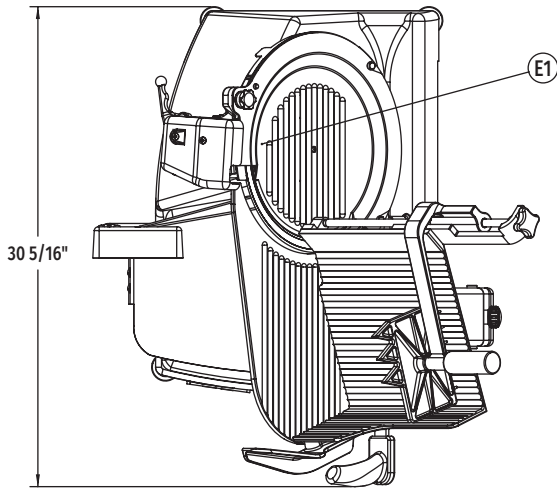

Top View

LEGEND

Electrical Connections	
E1	120/60/1; 5.6 Amps

WARNING: Electrical and grounding connections must comply with the applicable portions of the National Electrical Code and/or other local electrical codes.

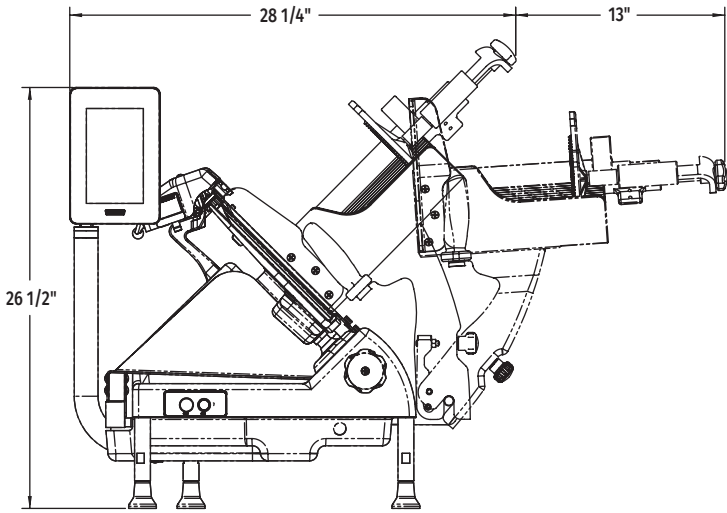

Side View

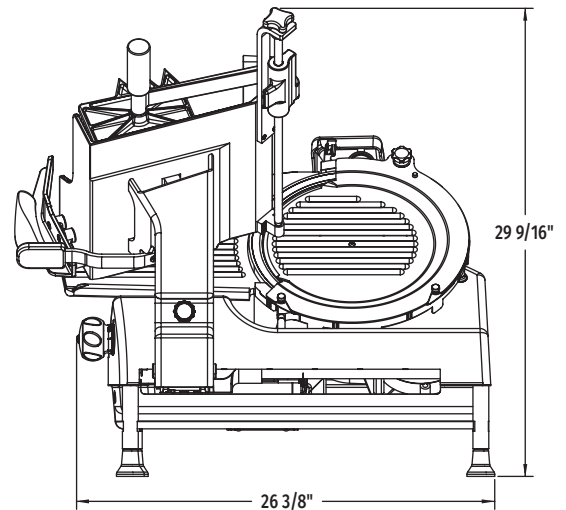

Back View