



Project \_\_\_\_\_  
 AIA # \_\_\_\_\_ SIS # \_\_\_\_\_  
 Item # \_\_\_\_\_ Quantity \_\_\_\_\_ C.S.I. Section 114000



## HTm Scale



HTm Scale



HTm Self-Service Scale with Large Elevated Display



## SPECIFIER STATEMENT

HTm Scales include a dual-core processor and Linux operating system. HT scales weigh, automatically compute a price from stored PLU's, and print a label. The HTm scales are equipped with latest ValueMax and CodeChecker technology to optimize accuracy and print head life. The HTm scales utilize Hobart's patented three screen swipe technology user interface for operator ease of use.

## MODELS

Model	Feature	Operating System	Available Storage
<input type="checkbox"/> HTm-LH	No GCD	Linux	32 GB
<input type="checkbox"/> HTm-7LH	7" GCD	Linux	32 GB
<input type="checkbox"/> HTm-7ELH	7" Elevated	Linux	32 GB
<input type="checkbox"/> HTm-SSLS	Self Service	Linux	32 GB
<input type="checkbox"/> HTm-SSLSB	Self Service w/Barcode Scanner	Linux	32 GB

## STANDARD FEATURES

- + ValueMax detects and compensates up to 3° out-of-level
- + CodeChecker provides diagnostics of print head health for planned regular maintenance and cleaning
- + On-demand dual core processor for energy savings
- + Cassette label loading system
- + Video capability allowing independent videos on operator and customer screens
- + Intuitive and customizable graphical user interface
- + Built-in wireless and wired Ethernet, out of the box
- + Swipe between three screens for operator ease of use
- + Search database by description, keyword, or PLU
- + Best seller keys by scale/department
- + Flash keys can be arranged by categories or groups
- + On-screen operator manual and tutorials
- + Operator, product, and/or recipe notes
- + On-screen alphanumeric keyboard and keypad
- + Ability to require operator login to track operator changes
- + COOL (country of origin labeling) can be created and modified on the scale
- + Default values for four types of products: Fixed Weight, By Count, Random Weight, and Fluid Ounces
- + UPC, EAN 13, EAN 128 Barcodes and GS1 Data Bar
- + Remotely access the scale using Hobart HTe software – operator and customer display views available
- + Applications run on the scale (Build-A-Meal, Multi-Department, etc.)

## SOFTWARE

- + Linux embedded operating system 
- + Interfaces with scale management software such as:
  - Invatron's PLUM
  - ADC's Interscale
  - Genesis Software
  - Data GateWeigh
  - HCT
  - Hobart HTe Software
    - Content management
    - Label editing
    - Remote updates

HT SCALE SERIES – HTm

Approved by \_\_\_\_\_ Date \_\_\_\_\_ Approved by \_\_\_\_\_ Date \_\_\_\_\_

## TECHNICAL SPECIFICATIONS

- + 10.1" touch screen operator display – WSVGA TFT LCD, LED backlit, 5 wire resistive type
- + 7" standard customer display – WSVGA TFT LCD, LED backlit
- + 14" touch screen on self-serve display
- + Dual-core processor
- + 2GB DDR3 RAM memory
- + 32GB micro SD RAM standard
- + Both 802.3 10/100/1000 Mbps Ethernet and 802.11 a/b/g/n/ac wireless out of box
- + Bluetooth 2.1
- + High resolution thermal print head for detailed graphics (store logos) and smaller bar codes – 203 dpi (8 dots per mm)
- + CodeChecker print head health agent
- + Accepted labels:
  - 1.5" and 2.25" width
  - 1" to 9.5" length die cut labels
  - Continuous labels
  - Oval labels

## SPECIFICATIONS

**Platter:** 14" wide x 15" deep

**Weigher Capacity:**

- 0 lb. - 12 lb. x 0.005 (0 - 6 kg x .002 kg)
- 12 lb. - 30 lb. x 0.01 (0 - 15 kg x .005 kg)

**ValueMax:** Up to 3° out-of-level compensation.

**Electrical:** 100-240 volts, 50-60 Hz, single phase, 1.42 amps, 170 watts max. 9 foot standard cord cap with ground type plug furnished.

**Media Support:** MPEG4, AAC, AVC/H.264

**Weights and Measures Certification:**

- + USA Certification – 13-101
- + Canada Certification – AM-6148C

**Environment:** Operating temperature limits are 14°F (-10°C) to 104°F (40°C) ambient. Scale operates satisfactorily in relative humidity of 10 to 85%.

**Shipping Weight:** 34 lbs.

**Shipping Weight Self-Service:** 50 lbs.

## DETAILS AND DIMENSIONS

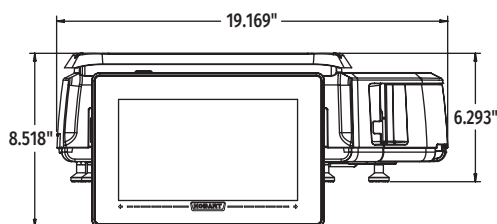
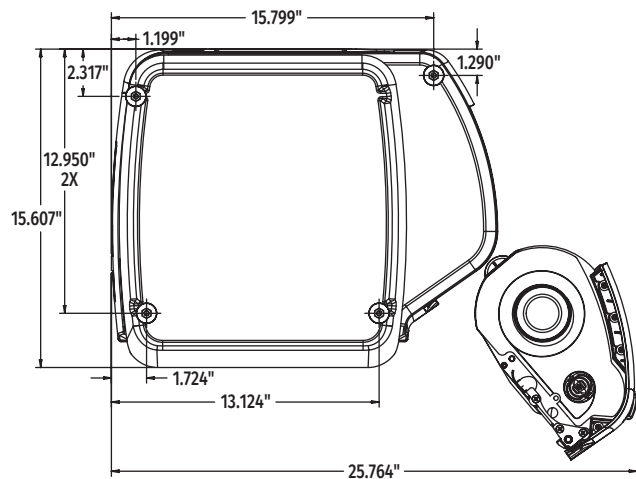

The below diagram reflects the customer facing panel for the HTm-7LH.

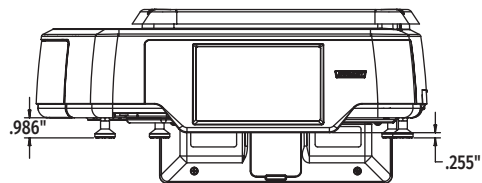

The below diagram reflects the customer facing panel for the HTm-LH.

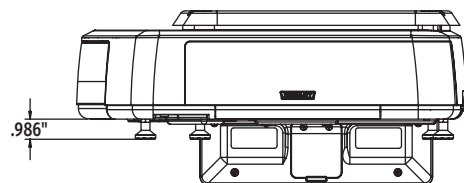

The customer facing panel for the HTm-LH is a solid black plate.

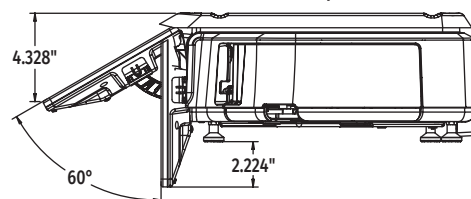

As continued product improvement is a policy of Hobart, specifications are subject to change without notice.