



Project _____
 AIA # _____ SIS # _____
 Item # _____ Quantity _____ C.S.I. Section 114000



PS40 Scale



MODEL

PS40-3 Includes Security Seal

STANDARD FEATURES

- + Simple touch key operation with audible “beep” response
- + Bright backlit displays
- + Up to 50 programmable keys; 12 direct, 38 indirect
- + Wipe clean keypad
- + Stainless steel platter
- + NSF approved
- + Legal for trade
- + Rechargeable battery with power cord (up to 80 hour battery life)
- + Ships pre-calibrated to end user

PS40 SCALE

SPECIFIER STATEMENT

The PS40 scale is a portioning and price computing scale with up to 50 programmable keys and a bright backlight display. The PS40 is NSF certified and features a stainless steel platter, wipe clean keypad and a rechargeable battery with a power cord to offer up to 80 hours of battery life.

Approved by _____ Date _____ Approved by _____ Date _____



SPECIFICATIONS

Capacity: 30 lbs. x 0.01 lbs.

Scale Housing: 13.9"W x 13"D x 4.9"H.

Platter: Stainless Steel, 12.8"L x 9.6"W.

Display: Backlit LCD displays, front and back; .75" high digits (20 mm); displays unit weight, unit price, and total price in 6 digit increments.

Keyboard: Membrane wipe down keyboard with audio feedback.

Electrical: AC plug in adaptor: Input 100-240V; Battery operation via 6V 4amp sealed rechargeable battery.

Operating Range: 14°F to 104°F; -10°C to +40°C.

Weight: Net: 9.3 lbs., Shipping: 15 lbs.

DETAILS AND DIMENSIONS

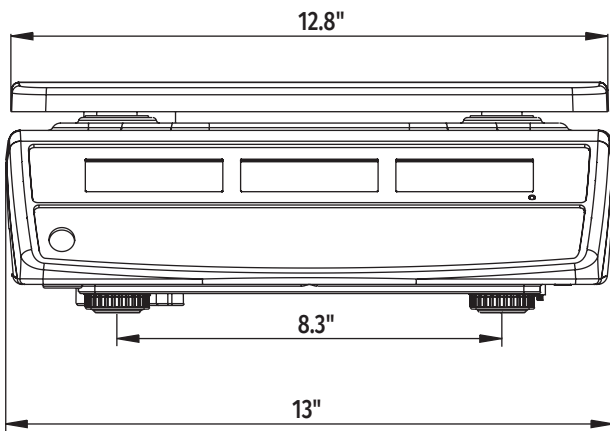

Front View

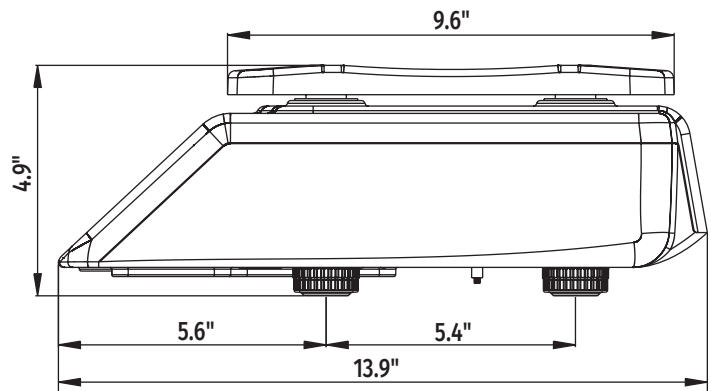

Side View

As continued product improvement is a policy of Hobart, specifications are subject to change without notice.