



701 S Ridge Avenue, Troy, OH 45374  
1-888-4HOBART • www.hobartcorp.com

# TURBOWASH II



## STANDARD FEATURES

- Type 300 series stainless steel construction
- 14 gauge stainless tanks and drain boards
- 11" high x 2½" deep back splash
- Stainless steel pump and impeller
- Self-draining pump
- Sink front trim panel
- Eight 1½" diameter wash nozzles
- Removable, welded H frame leg sets and adjustable bullet feet
- Detachable and adjustable height cross rails
- Dual inlet strainers
- Centrifugal pump with 2.5" diameter intake and 2" diameter outlet
- 2 H.P. totally enclosed (TEFC) wash pump motor with permanently sealed bearings
- Low water protection for wash pump motor
- Inherent motor overload protection, automatic reset

## DIRECTION FROM SOILED TO CLEAN END

- Right to Left
- Left to Right

## VOLTAGE

- 208-240/60/3
- 480/60/3

## OPTIONS AT ADDITIONAL COST

- 2" IPS sink drains (shipped loose)
- 2" IPS sink drains w/overflow (drains shipped loose)
- ¾" mixing faucets (shipped loose) Qty. \_\_\_\_
- ½" pre-rinse spray (shipped loose)
- Wash sink heater with high temperature and low water protection
- Adjustable (by Hobart service) pump shutdown timer
- High volume wash sink sump (12" x 12" x 3⅝" deep) with removable strainer
- Wash sink separator available (for wash sinks 42" or larger)
- Auto fill
- Utensil basket
- Hobart disposer with separate or single point electrical connection
- 15" deep over shelves with wall brackets Qty. \_\_\_\_
- 4' over shelf \_\_\_\_\_
- 6' over shelf \_\_\_\_\_
- 8' over shelf \_\_\_\_\_
- 10' over shelf (split 6' and 4') \_\_\_\_\_
- 12' over shelf (split 6' and 6') \_\_\_\_\_
- 14' over shelf (split 8' and 6') \_\_\_\_\_
- 16' over shelf (split 8' and 8') \_\_\_\_\_
- 18' over shelf (split 6, 4' and 8') \_\_\_\_\_
- 20' over shelf (split 2'-6' and 2'-4') \_\_\_\_\_
- Under shelf for clean end drain boards 30"and over
- Pan rack, 7 pan capacity
- Chemical pumps

Specifications, Details and Dimensions on Inside and Back.



ANSI/NSF 2  
Sanitation



# TURBOWASH II

# HOBART

701 S Ridge Avenue, Troy, OH 45374  
1-888-4HOBART • www.hobartcorp.com

## DETAILS AND DIMENSIONS

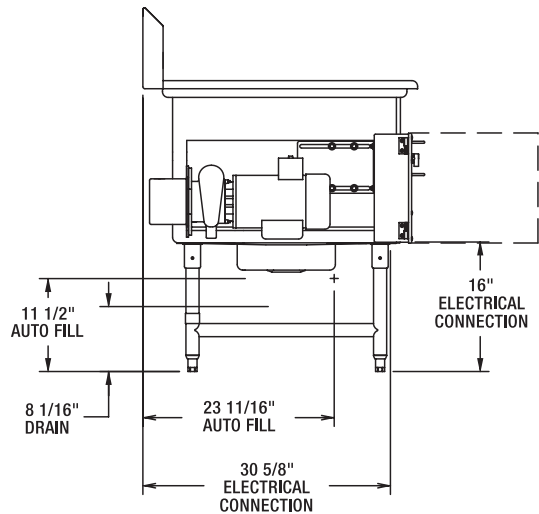
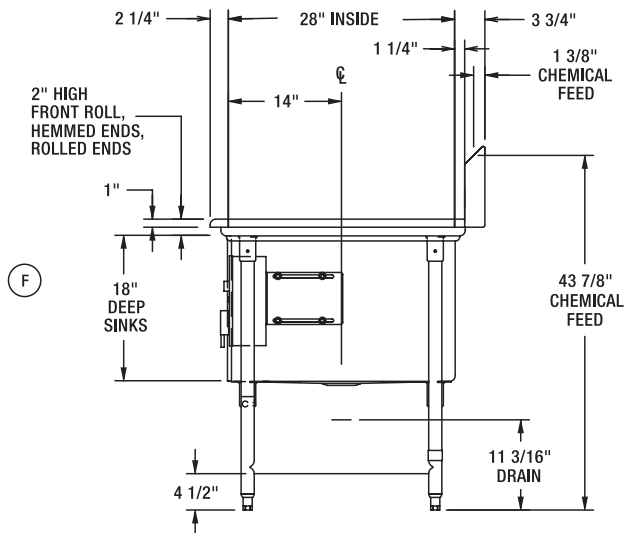
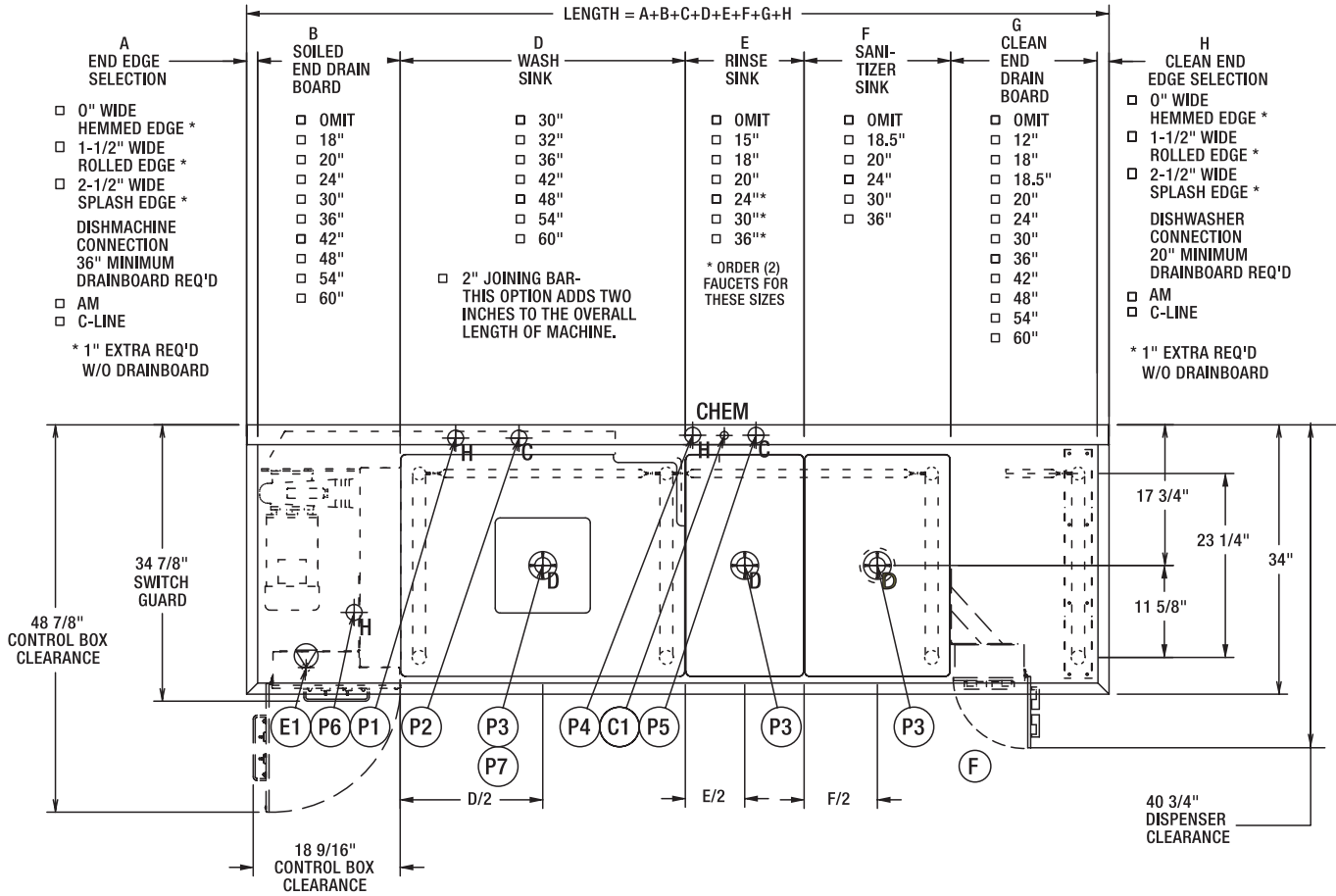

749865  
TurboWash II  
W/DRAINBOARDS  
L-R OPERATION  
REV. F



701 S Ridge Avenue, Troy, OH 45374  
1-888-4HOBART • www.hobartcorp.com

# TURBOWASH II

TurboWash II WITH ELECTRIC HEAT			
ELEC. SPECS.	RATED AMPS	MINIMUM SUPPLY CIRCUIT CONDUCTOR AMPACITY	MAXIMUM OVERCURRENT PROTECTIVE DEVICE
208-240/60/3	17.0	20	20
480/60/3	10.2	15	15

TurboWash II (W/O ELECTRIC HEAT)			
ELEC. SPECS.	RATED AMPS	MINIMUM SUPPLY CIRCUIT CONDUCTOR AMPACITY	MAXIMUM OVERCURRENT PROTECTIVE DEVICE
208-240/60/3	5.6	15	15
480/60/3	5.1	15	15

### WARNING

ELECTRICAL AND GROUNDING CONNECTIONS MUST COMPLY WITH THE APPLICABLE PORTIONS OF THE NATIONAL ELECTRICAL CODE AND/OR OTHER LOCAL ELECTRICAL CODES.

PLUMBING CONNECTIONS MUST COMPLY WITH APPLICABLE SANITARY, SAFETY, AND PLUMBING CODES.

### CONNECTION INFORMATION LEGEND (\*AFF - ABOVE FINISHED FLOOR)

- C1 CHEMICAL FEED CONNECTION: (OVER PRIMARY FAUCET), 1" DIA. HOLE FOR HOSE GROMMET, 43-7/8" AFF.
- E1 ELECTRICAL CONNECTION: MOTORS AND CONTROLS (INCLUDES ELECTRIC HEAT WHEN ORDERED), 3/4" CONDUIT, 16" AFF.
- P1 HOT WATER CONNECTION: PRE-RINSE SPRAYER (WHEN ORDERED), 1/2" FPT, 36-15/16" AFF.
- P2 COLD WATER CONNECTION: PRE-RINSE SPRAYER (WHEN ORDERED), 1/2" FPT, 36-15/16" AFF.
- P3 SINK DRAINS: (1-3 CONNECTIONS-WHEN ORDERED), 2" MPT, 11-3/16" AFF.
- P4 HOT WATER CONNECTION: MIXING FAUCET (WHEN ORDERED), 3/4" FPT, 36-5/8" AFF.
- P5 COLD WATER CONNECTION: MIXING FAUCET (WHEN ORDERED), 3/4" FPT, 36-5/8" AFF.
- P6 HOT WATER CONNECTION: AUTO FILL (WHEN ORDERED), 3/4" FPT, 11-1/2" AFF.
- P7 WASH SINK WITH STRAINER DRAIN CONNECTION (WHEN ORDERED), 2" MPT, 8-1/16" AFF.

ALL DIMENSIONS TAKEN FROM FINISHED FLOOR LINE MAY INCREASE 3/4" OR DECREASE 1/2" DEPENDING ON LEG ADJUSTMENT. RECOMMENDED 7-3/4" AFF WALL DRAIN LOCATION.

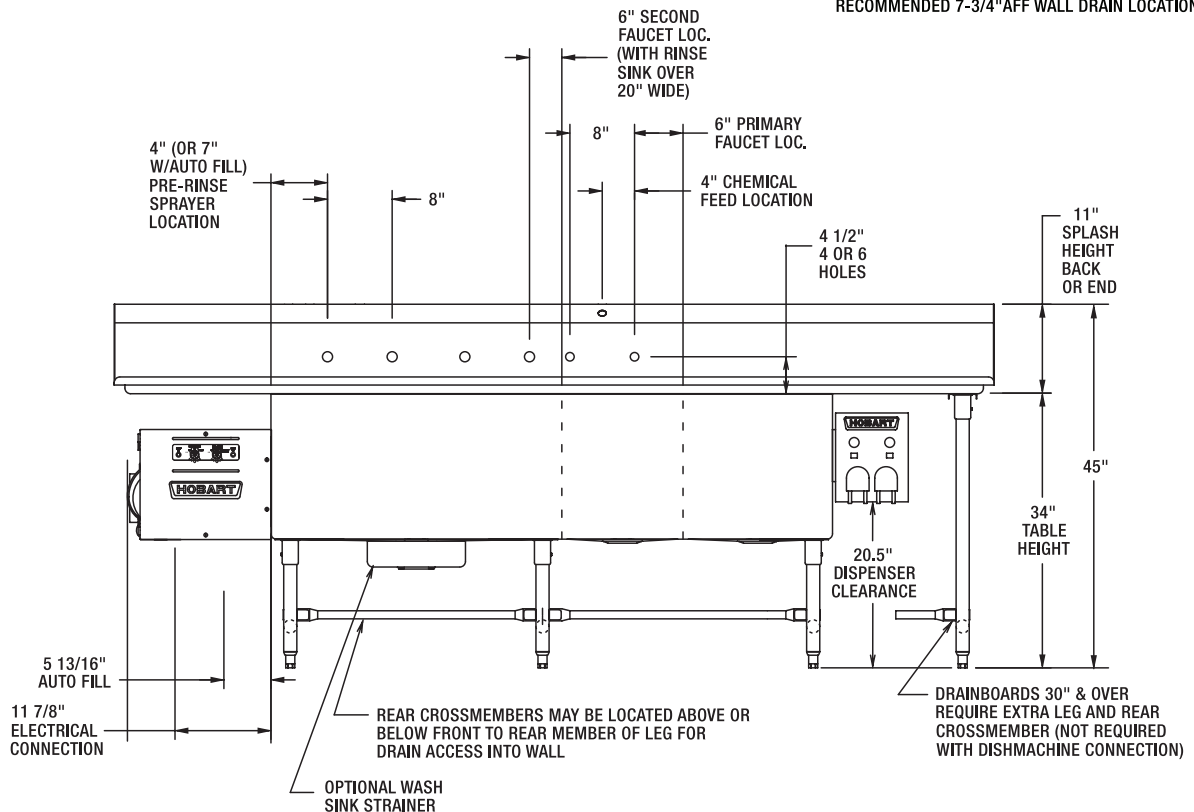

# TURBOWASH II



701 S Ridge Avenue, Troy, OH 45374  
1-888-4HOBART • www.hobartcorp.com

As continued product improvement is a policy of Hobart, specifications are subject to change without notice.