

HOBART701 S Ridge Avenue, Troy, OH 45374
1-888-4HOBART • www.hobartservice.com**WATER SOFTENING SYSTEMS –
WS-55****HOBART****FEATURES:****Operating Profile**

Water is filtered to NSF 42 & 53 standards for particulate, chlorine, chloramine, taste and odor using replaceable cartridge filtration. Softener will remove hardness to less than 1/2 gpg when operated in accordance with the operating instructions. The system includes two tanks. This duplex configuration operates with one tank on-line during service. During regeneration cycles, one tank provides water to service and to the regenerating tank. A water meter initiates system regeneration. The water meter measures the processed volume and is adjustable. Service flow is down-flow and regeneration flow is up-flow.

CB15K Hollow Carbon Filter

The CB15K Hollow Carbon Filter located inside of the WS-55 cabinet is NSF 42 & 53 certified up to 15,000 gallons for the reduction of Chloramine. The filter is replaced based on psi or 15,000 gallon capacity. Maximum working pressure of the filter is 125 psi.

Regeneration Control Valve

The regeneration control valve is top mounted (top of media tank), and manufactured from non-corrosive materials. Control valve does not weigh more than four pounds. Control valve provides service and regeneration control for two media tanks. Inlet and outlet ports accept a quick connect, double o-ring sealed adapter. Interconnection between tanks is made through the regeneration valve with a quick connect adapter. Control valve operates using a minimum inlet pressure of 15 psi. Pressure is used to drive all valve functions. No electric hook-up is required. Control valve will incorporate four operational cycles including; service, brine draw, slow rinse, and a combined fast rinse and brine refill. Service cycle operates in a down-flow direction. The brine cycle flows up-flow, opposite the service flow, providing a countercurrent regeneration. Control valve contains a fixed orifice eductor nozzle and self-adjusting backwash flow control. The control valve will prevent the bypass of hard water to service during the regeneration cycle.

Media Tanks

The tanks are designed for a maximum working pressure of 125 psi and hydrostatically tested at 300 psi. Tanks are made of engineered plastic with a 2.5 in. threaded top opening. Each tank is NSF approved. Upper distribution system is of a slot design. Lower distribution system is of a flat plate design. Distributors will provide even flow of regeneration water and the collection of processed water.

Conditioning Media

Each softener includes uniform bead cation resin having a minimum exchange capacity of 30,000 grains/ft³ when regenerated with 15.0 lbs/ft³. The media is solid, of a proper particle size and contains no plates, shells, agglomerates or other shapes, which might interfere with the normal function of the water softener.

Brine System

A combination salt storage and brine production tank is manufactured of corrosion resistant, plastic. The brine tank has a chamber to house the brine valve assembly. The brine float assembly allows for adjustable salt settings and provides for a shut-off to the brine refill. The brine tank includes a safety overflow connection to be plumbed to a suitable drain.

Salt Alarm

Salt alarm consists of an alarm box and a brine sensor. Brine sensor is mounted internally on the grid plate and operates on the specific gravity of proper brine concentration. An alarm condition is triggered when the concentration falls below acceptable level for more than 15 minutes. The alarm is both an 80-db audible alarm every 3 seconds and a red LED flash every 7 seconds. The alarm box operates on three AA batteries and connects to the brine sensor with a standard 2-wire phone cord (7' phone cord supplied).

MODEL: **Model WS-55**

Specifications, Details and Dimensions on Back.

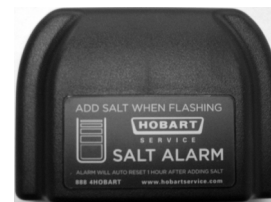
**Model WS-55****Salt Alarm****WATER SOFTENING SYSTEMS - WS-55**

WATER SOFTENING SYSTEMS – WS-55



701 S Ridge Avenue, Troy, OH 45374
1-888-4HOBART • www.hobartservice.com

System Components

Filter.....CB15K
 Filter Media.....Hollow Carbon
 Filter Capacity.....15,000 Gallons
 Filter Dimension.....14"W x 9"D x 23 7/8" H
 Media Vessel (qty) Size(2) 8 x 17"
 Media Vessel ConstructionFiberglass Wrapped Engineered Plastic
 Empty Bed Volume0.40 ft³
 Media TypeUniform Bead Cation Resin
 Media Volume0.40 ft³
 Bed DepthPacked
 Free Board None
 Riser Tube1" CPVC
 Distributor
 Upper0.012" Slots, Engineered Plastic Basket
 Lower0.009" Slots, Stainless Steel Flat Plate
 Under beddingNone
 Regeneration ControlNon-electric Use Meter
 Regeneration TypeCountercurrent
 Meter Type0.05 - 5.00 gpm Polypropylene Turbine

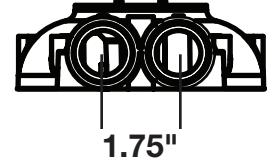

Inlet Water Quality

Pressure Range40 – 125 psi Dynamic Pressure
 Temperature Range40 – 100° F
 pH Range5 – 10 SU
 Free Chlorine Cl₂ (Max.)2.0 mg/l
 Hardness as CaCO₃ (Max.)40 gpg
 Chloramine4.0 mg/l

Operating Specs

Flow Range (15 / 30 psig)0.05 – 3.7 gpm
 Flow ConfigurationAlternating
 Dimensions (width x depth x height)20 x 22 x 28"
 Alarm Box5.5" w x 1.375" D x 4"H
 Weight (Operating / Shipping)240 / 120 lbs.
 Flow PathCB15K - Softener

Connections

Inlet / Outlet Connections3/4" NPT Flex Hose
 Drain Connection0.5" Tube
 Brine Line Connection0.375" Tube (internal)
 Overflow Connection0.5" Tube
 PowerNone
 Salt Alarm.....3 AA Batteries

System Part Numbers

WS-55, Compact Cabinet Softener/CB15K.....913091-124

Brine Tank Options

Tank Description208 Cabinet
 Tank Height28"
 Tank Footprint20 x 22"
 MaterialHDPE
 Salt Capacity55 lbs.

Regeneration Specifications

Regeneration Volume14 gallons
 Regeneration Time11 minutes
 Backwash Flow Control1.40 gpm
 Brine Refill Flow Control0.40 gpm

Setting	Capacity	Efficiency	Dosing	Disc Selection (Compensated Hardness*)							
				Meter Disc	1	2	3	4	5	6	7
1.4 lbs.	4,818 grains	3,442 gr./lb.	3.5 lbs./ft ³	6	13	25	27	30	35	37	40
Gallons/Regeneration:				591	296	166	148	118	99	84	74
Flow during regeneration (@ 15 psig):				5	5	5	5	5	5	5	5

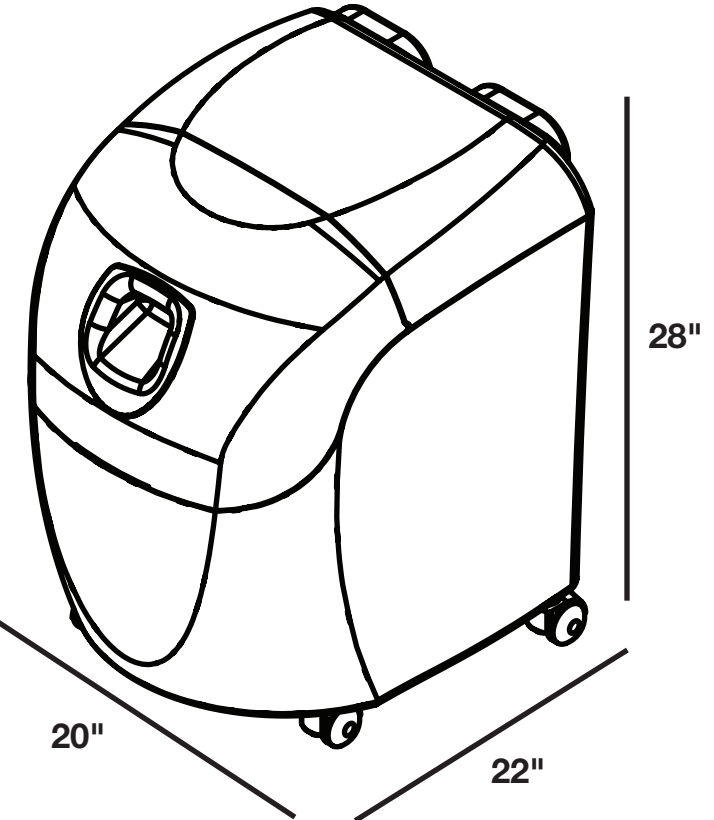

*Compensated hardness in gpg = Hardness + (3 x Fe in mg/l)

As continued product improvement is a policy of Hobart, specifications are subject to change without notice.