

**HOBART**701 S Ridge Avenue, Troy, OH 45374  
1-888-4HOBART • www.hobartservice.com**WATER SOFTENING SYSTEMS –  
WS-80****HOBART****FEATURES:****Operating Profile**

Softener will remove hardness to less than 1/2 gpg when operated in accordance with the operating instructions. The system includes two tanks. This duplex configuration operates with one tank on-line during service. During regeneration cycles, one tank provides water to service and to the regenerating tank. A water meter initiates system regeneration. The water meter measures the processed volume and is adjustable. Service flow is down-flow and regeneration flow is up-flow.

**Regeneration Control Valve**

The regeneration control valve is top mounted (top of media tank), and manufactured from non-corrosive materials. Control valve does not weigh more than four pounds. Control valve provides service and regeneration control for two media tanks. Inlet and outlet ports accept a quick connect, double o-ring sealed adapter. Interconnection between tanks is made through the regeneration valve with a quick connect adapter. Control valve operates using a minimum inlet pressure of 15 psi. Pressure is used to drive all valve functions. No electric hook-up is required. Control valve will incorporate four operational cycles including; service, brine draw, slow rinse, and a combined fast rinse and brine refill. Service cycle operates in a down-flow direction. The brine cycle flows up-flow, opposite the service flow, providing a countercurrent regeneration. Control valve contains a fixed orifice eductor nozzle and self-adjusting backwash flow control. The control valve will prevent the bypass of hard water to service during the regeneration cycle.

**Media Tanks**

The tanks are designed for a maximum working pressure of 125 psi and hydrostatically tested at 300 psi. Tanks are made of engineered plastic with a 2.5 in. threaded top opening. Each tank is NSF approved. Upper distribution system is of a slot design. Lower distribution system is of a flat plate design. Distributors will provide even flow of regeneration water and the collection of processed water.

**Conditioning Media**

Each softener includes uniform bead cation resin having a minimum exchange capacity of 30,000 grains/ft<sup>3</sup> when regenerated with 15.0 lbs/ft<sup>3</sup>. The media is solid, of a proper particle size and contains no plates, shells, agglomerates or other shapes, which might interfere with the normal function of the water softener.

**Brine System**

A combination salt storage and brine production tank is manufactured of corrosion resistant, plastic. The brine tank has a chamber to house the brine valve assembly. The brine float assembly allows for adjustable salt settings and provides for a shut-off to the brine refill. The brine tank includes a safety over-flow connection to be plumbed to a suitable drain.

**Salt Alarm**

Salt alarm consists of an alarm box and a brine sensor. Brine sensor is mounted internally on the grid plate and operates on the specific gravity of proper brine concentration. An alarm condition is triggered when the concentration falls below acceptable level for more than 15 minutes. The alarm is both an 80-db audible alarm every 3 seconds and a red LED flash every 7 seconds. The alarm box operates on three AA batteries and connects to the brine sensor with a standard 2-wire phone cord (7' phone cord supplied).

**MODEL:** **Model WS-80**

Specifications, Details and Dimensions on Back.



Model WS-80

Salt Alarm

**WATER SOFTENING SYSTEMS - WS-80**

# WATER SOFTENING SYSTEMS – WS-80



701 S Ridge Avenue, Troy, OH 45374  
1-888-4HOBART • www.hobartservice.com

## System Components

Media Vessel (qty) Size .....(2) 8 x 17"  
Media Vessel Construction .....Fiberglass Wrapped Engineered Plastic  
Empty Bed Volume .....0.40 ft<sup>3</sup>  
Media Type .....Uniform Bead Cation Resin  
Media Volume .....0.40 ft<sup>3</sup>  
Bed Depth .....Packed  
Free Board ..... None  
Riser Tube .....1" CPVC  
Distributor  
Upper .....0.012" Slots, Engineered Plastic Basket  
Lower .....0.009" Slots, Stainless Steel Flat Plate  
Under bedding .....None  
Regeneration Control .....Non-electric Use Meter  
Regeneration Type .....Countercurrent  
Meter Type .....0.30 - 25.00 gpm Polypropylene Turbine

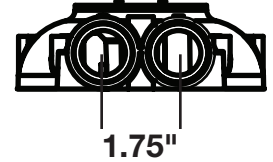

## Inlet Water Quality

Pressure Range .....15 – 125 psi Dynamic Pressure  
Temperature Range .....35 – 150° F  
Temperature (Continuous) .....< 150° F  
pH Range .....5 – 10 SU  
Free Chlorine Cl<sub>2</sub> (Max.) .....2.0 mg/l  
Hardness as CaCO<sub>3</sub> (Max.) .....40 gpg

## Operating Specs

Flow Range (15 / 30 psig) .....10.2 – 16.4 gpm  
Flow Configuration .....Alternating  
Dimensions (width x depth x height) .....20 x 22 x 28"  
Weight (Operating / Shipping) .....220 / 100 lbs.

## Connections

Inlet / Outlet Connections .....Custom Adapter and Bracket  
Drain Connection .....0.5" Tube  
Brine Line Connection .....0.375" Tube (internal)  
Overflow Connection .....0.5" Tube  
Power .....None  
Salt Alarm.....3 AA Batteries

## System Part Numbers

WS-80, Compact Cabinet Softener .....00-913091-00125

## Brine Tank Options

Tank Description .....208 Cabinet  
Tank Height .....28"  
Tank Footprint .....20 x 22"  
Material .....HDPE  
Salt Capacity .....80 lbs.

## Regeneration Specifications

Regeneration Volume .....14 gallons  
Regeneration Time .....11 minutes  
Backwash Flow Control .....1.40 gpm  
Brine Refill Flow Control .....0.40 gpm

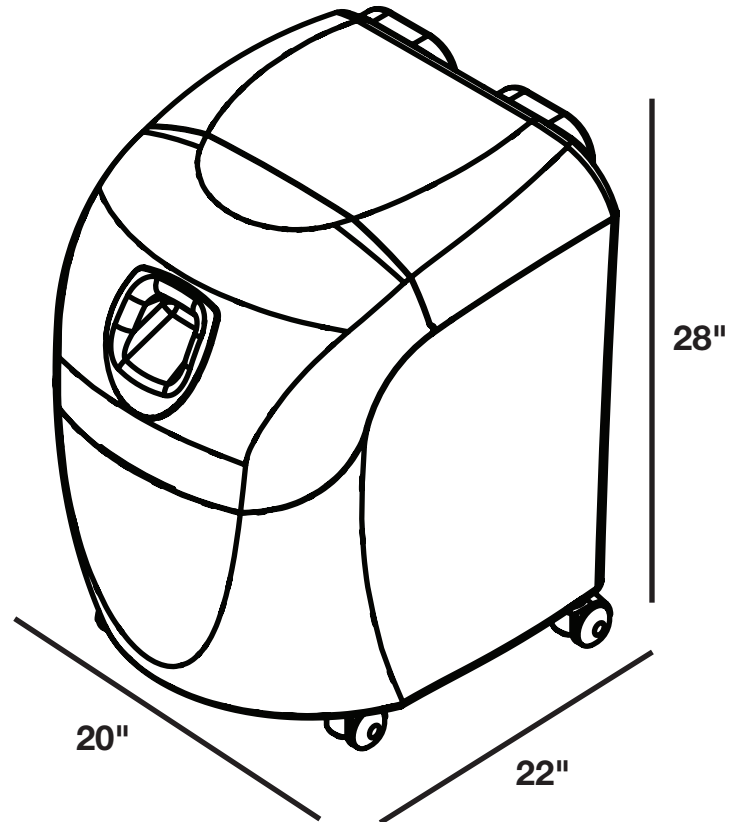

## Disc Selection

(Compensated Hardness\*)

Setting	Capacity	Efficiency	Dosing	Meter Disc	1	2	3	4	5	6	7	8
1.4 lbs.	4,818 grains	3,442 gr./lb.	3.5 lbs./ft <sup>3</sup>		5	11	17	22	27	32	35	40
			<b>Gallons/Regeneration:</b>		732	366	244	183	146	122	105	92
			<b>Flow during regeneration (@ 15 psig):</b>		10.2	10.2	10.2	10.2	10.2	8.3	6.7	5.5

\*Compensated hardness in gpg = Hardness + (3 x Fe in mg/l)

As continued product improvement is a policy of Hobart, specifications are subject to change without notice.